

Air-piloted Valves Features

- Since the unit requires air piping only, with no need for electrical wiring, it can be handled by a person without fear of electrical shocks or current leakage.
- Using no electricity means that expensive equipment to protect against explosions, special precautions, or measures against electric noise are not to be required.
- Unlike electrical equipment, the construction is simple. The associated limit valve is also durable and can be used for long periods.
- Because harmless compressed air is used, there is no need for major construction work on the main or pilot air line unlike that of hydraulic piping, and piping work is simple enough for anyone trained to perform.
- The power source is always compressed air, so that the system can be easily used where no power supply exists. In addition, it retains memory for about several dozen minutes, and can therefore continue operations even during power outages.

Koganei Air-piloted Valves Features

Assured operation

Sharp, switching characterized by poppet and diaphragm construction. The valve seat is also reliable. (Quick switching of main pressure helps to keep valve seat seal performance.)

Few breakdowns occur in this construction.

The construction is extremely simple. A poppet valve prevents galling or other problems, even if small foreign objects have entered inside. And no sticking occurs even if the unit is left unused for long periods of time.

It can be used without lubrication.

With virtually no sliding parts, there is no need for lubrication other than for a few specific models. This means no breakdown due to insufficient lubrication.

Tolerates frequent operations for long operating life

The small mass and stroke of the moving parts means a small inertial force which, along with construction with the large-capacity synthetic rubber for absorbing impacts, ensures continuous high-frequency operations and a long operating life.

Any mounting direction acceptable

No matter what direction is used for mounting, the construction causes no trouble to the operation.

Compact and lightweight

A unique, compact design, with a body of light aluminum alloy.

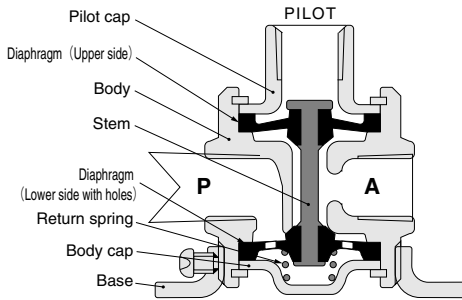

Diaphragm type basic construction (125A type)

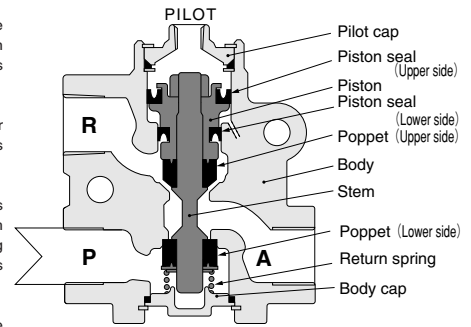

Piston poppet-type basic construction (501A type)

Application Examples of Air-piloted Valves

Using as a large-sized stop valve

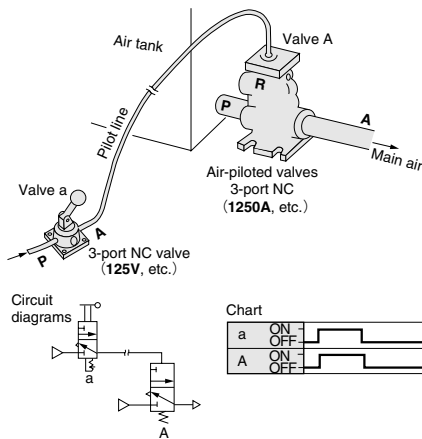

Air cylinder operation

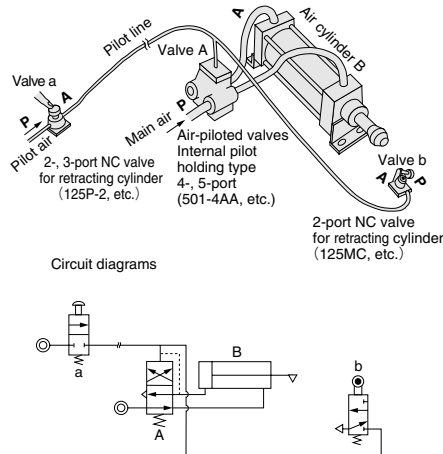

Switching of air pressure signal

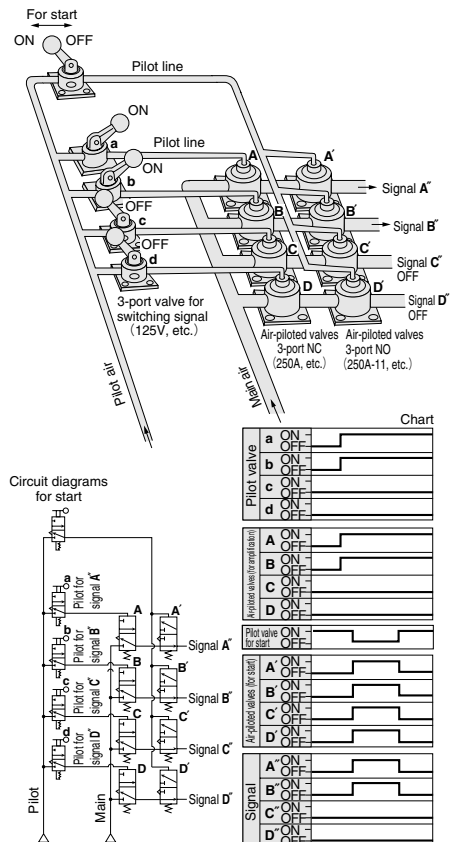

Air cylinder operation

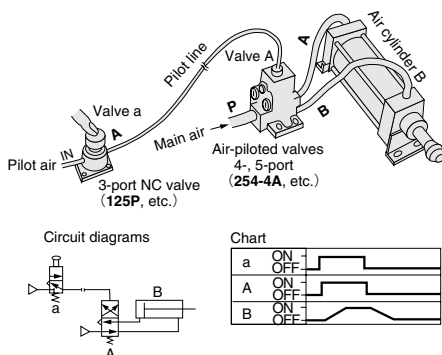

The air cylinder rod extends only as long as pilot valve **a** is pressed down.

Charts for Selection of Air-piloted Valves

● 2-, 3-port valve (air flow rate of each model)

Model of air-piloted valve	Air flow rate ℓ /min [ft. ³ /min.] (Supply pressure 0.5MPa [73psi.] when outlet port vents to the air)							
	200	300	400	1000	2000	3000	10000	20000
3P+34A (TAC valve)	120 [4.2]							
31P+341A (TAC ² valve)	370 [13.1]							
125A	370 [13.1]							
250A 2503A	1000 [35.3]							
500A	3700 [131]							
375A 501A	4700 [166]							
750A	9300 [328]							
1000A 1250A	18600 [657]							

● 4-, 5-port valve (applicable cylinder bore size of each model)

Model of air-piloted valve	Cylinder bore size mm [in.]									
	φ20 [0.787]	25.32 [0.984/1.260]	40 [1.575]	50 [1.969]	63 [2.480]	80 [3.150]	100 [3.937]	125 [4.921]	140 [5.512]	180 [7.087]
4P+34A (TAC valve)	This area presents high cylinder speed is not required.									
41P+341A (TAC ² valve)	Normal operating range (Cylinder speed 300~500mm/s [11.8~19.7in./sec.] Cylinder speed (/max. 200~300mm/s [7.9~11.8in./sec.], min. 50mm/s [2.0in./sec.]									
250-4A 2503-4A	This area presents high cylinder speed is required.									
254-4A										
375-4A 501-4A										
750-4A										
1000-4A 1250-4A	(Cylinder speed: min. 500~600mm/s [19.7~23.6in./sec.]									

- Notes :
1. While the speeds shown in this graph assume an air supply pressure of 0.5MPa [73psi.] and a load ratio of 0, the speeds will be virtually the same in the range of 0.4~0.7MPa [58~102psi.], and up to a load ratio of about 30 %.
 2. In general, select a valve with a margin of about 50 % for the required cylinder speed, and then use a speed controller to reduce the speed in operation.
 3. In considering the time required for the cylinder to make one stroke, the "cylinder delay time" and "cushioning time" need to be considered alongside the "cylinder speed."

Differences between A Type and AA Type Air-piloted Valves

A type valves (Continuous pilot pressure is needed to maintain the operating condition.)

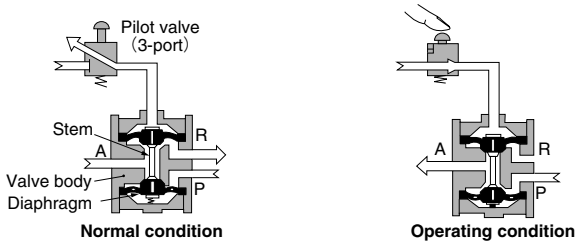

AA type Valves (The difference from the A type valve is the existence of a bypass hole (small hole) on the stem. This helps the pilot valve to maintain its operating condition during a momentary operation. It is able to maintain the operating condition even if a certain amount of air leaks from the pilot line.)

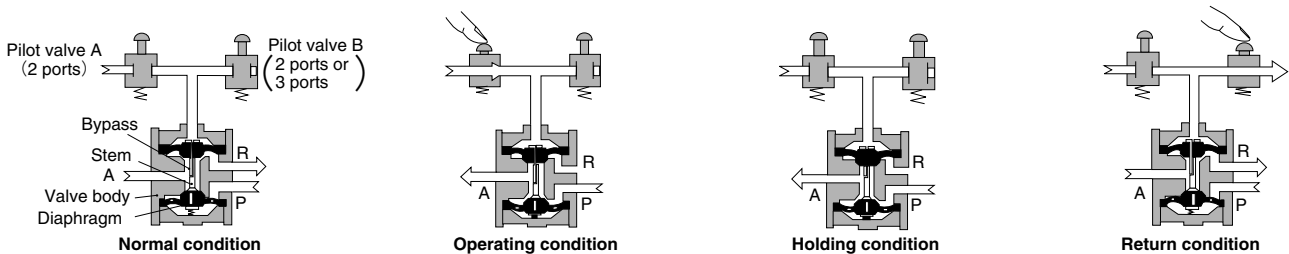

Note : These schematic diagrams show the diaphragm type, 3-port valves. The bypass for the 4-, 5-port valve is on the A side stem. See the Operating Principles for the 250-4 AA type on p.946.

Safety Precautions (Air-piloted valves)



Warning

1. All types other than the A2 (double pilot) type are designed to use air as the media. For other media, consult us.
2. Always check the Catalog, etc., when performing piping to products to ensure that the connections are correctly done. Wrong piping could result in abnormal operation of the actuator, etc.



Caution

For locations subject to water or to large amounts of dust, use a cover, etc., to protect the valve. In addition, install a muffler, etc., to the R port to prevent entering of dust. Intrusion of water or dust could result in short-term functional breakdowns, or in sudden drops in performance or reduced operating life.



Others

1. Use main air pressure higher than the minimum operating pressure listed in the Catalog.
2. Set the pilot pressure to a level suitable to the main pressure. An unnecessarily high pressure can shorten the operating life.
3. If excessively throttling the R port for operation, set the pilot pressure at the main pressure or higher (A type). For details, see the specifications of each series.
4. The AA type (internal pilot holding type) cannot be used as a 2-port valve. For a large air flow rate, provide sufficient air supply. In addition, the R port cannot be used in a choked condition. Install speed controllers between the valve and cylinder.
5. As with the normal A type, use a pilot valve size that offers enough margin when the AA type is operated as a single pilot valve. In this case, set the main and pilot valves to the same pressure.

Piston Poppet Type Air-Piloted Valves Rc1/4~3/8

254 Series

Symbols

Spring return normal type (A type)	Spring return internal pilot holding type (AA type)
4-port	
254-4A 254-4A-03	254-4AA 254-4AA-03

Specifications

Item	Basic model	A type (normal type)		AA type (internal pilot holding type)	
		254-4A	254-4A-03	254-4AA	254-4AA-03
Port size Rc	Main	1/4	3/8	1/4	3/8
	Pilot	1/8			
Effective area [Cv]	mm ²	15 [0.76]			
Media		Air			
Operating pressure range MPa [kgf/cm ²] [psi.]	Main	0~0.9 [0~9.2] [0~131]		0.1~0.9 [1.0~9.2] [15~131]	
	Pilot	See the table "Minimum Pilot Pressure"		0.1~0.9 [1.0~9.2] [15~131] (Use at the same pressure as the main pressure)	
Proof pressure MPa [kgf/cm ²] [psi.]		1.35 [13.8] [196]			
Operating temp. range (atmosphere and media) °C [°F]		0~60 [32~140]			
Maximum operating frequency Hz		6			
Lubrication		Not required			
Mass kg [lb.]		0.8 [1.8]			

Order Codes

● A type (normal type)

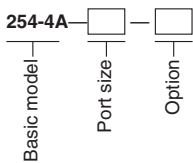

Port size

Code	Port size Rc
Blank	1/4
03	3/8

Option

Code	Specification
70	With speed controller

● AA type (internal pilot holding type)



Port size

Code	Port size Rc
Blank	1/4
03	3/8

A built-in type speed controller cannot be installed into the 254-4AA type.
Install a separate speed controller (KSC21, KSC31, etc.) between the valve and cylinder.

Flow Rate

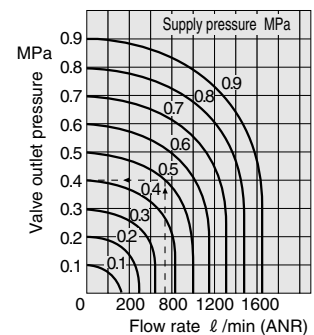

How to read the graph

When the supply pressure is 0.5MPa [73psi.] and the flow rate is 740 l/min [26.1ft³/min.] (ANR), the valve outlet pressure becomes 0.4MPa [58psi.].

1MPa = 145psi., 1 l/min = 0.0353ft³/min.

Operating Principles, Major Parts and Materials

● Normal condition

● Operating condition

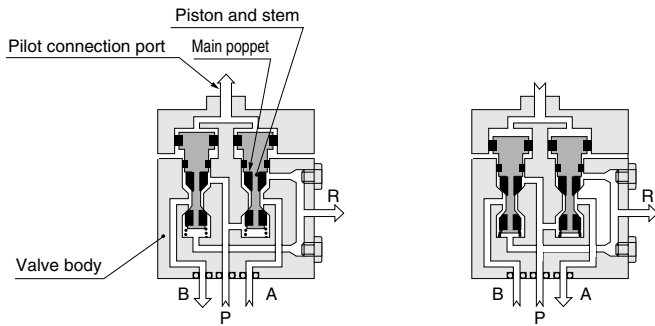

Note: The AA type (internal pilot holding type) is identical, except for the bypass hole (small hole) on the A side stem. For the operating principles and methods of use, see p.940.

Parts	Materials
Body	Aluminum alloy (anodized)
Stem	Brass
Poppet	Synthetic rubber
Seal	

Minimum Pilot Pressure

Model	Main pressure MPa [psi.]					
	0 [0]	0.1 [15]	0.3 [44]	0.5 [73]	0.7 [102]	0.9 [131]
254-4A	0.1	0.15	0.22	0.3	0.4	0.5
254-4A-03	[15]	[22]	[32]	[44]	[58]	[73]

Note: Set the AA type pilot pressure to the same as the main pressure.

Time Required for Switching by Pilot Line Length

(Both main and pilot 0.5MPa [73psi.]
Pilot line inner diameter 4mm [0.16in.]

Model		Pilot line length L m [ft.]				
		2 [6.6]	6 [19.7]	10 [32.8]	50 [164]	100 [328]
254-4A	ON	0.15	0.2	0.3	1.6	3.0
	OFF	0.2	0.35	0.5	2.8	7.1

How to read the table

For example, when using a 10m [32.8ft.] pilot line to send a signal, it takes 0.3 second for the switching operation to turn it on and 0.5 second to turn it off.

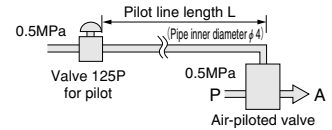

Dimensions (mm)

● 254-4A

● 254-4AA

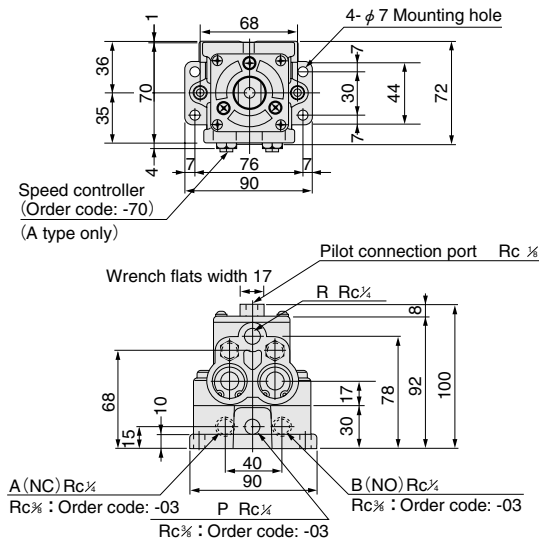

Notes: 1. To change the speed controller installed position to the A port side, just rotate the valve body by 180 degrees. In this case, B becomes NC, while A becomes NO.

2. A built-in speed controller cannot be installed into the 254-4AA type.

Piston Poppet Type Rc1/4~3/8 Manifold Air-piloted Valves

M254 Series

Order Codes

Number of units	Stn. 1~3	M254-4A
	Stn. 4	M254-4AA
	Stn. 5	BP
	Stn. 6	M254-4E1-70-AC100V
Station		Valve model

● Number of units (number of mounting valves)	
Code	Number of units
2	2
3	3
⋮	⋮
6	6

● Station (valve mounting position)	
Code	Details
Stn.1	1st position from the left when facing the A, B ports.
Stn.2	2nd position from the left when facing the A, B ports.
Stn.3	3rd position from the left when facing the A, B ports.
⋮	⋮
Stn.6	6th position from the left when facing the A, B ports.

● Valve model	
	Model
	M 254-4A
	M 254-4AA
	M 254-4E1
	M 254-4E2
	M 254-4SE2
	Block-off plate (Order code: BP)

Enter the valve models required for each station.

- Note: 1. The prefix **M** of each valve model signifies a "solenoid valve for manifolds." Enter **M** in every order code. The order code for the valpack cylinder is **M254-4E1-70** or **M254-4A-70**.
2. The "block-off plate" is used to close unused stations.

Dimensions (mm)

Unit dimensions

Code	L
M2	175
M3	260
M4	345
M5	430
M6	515

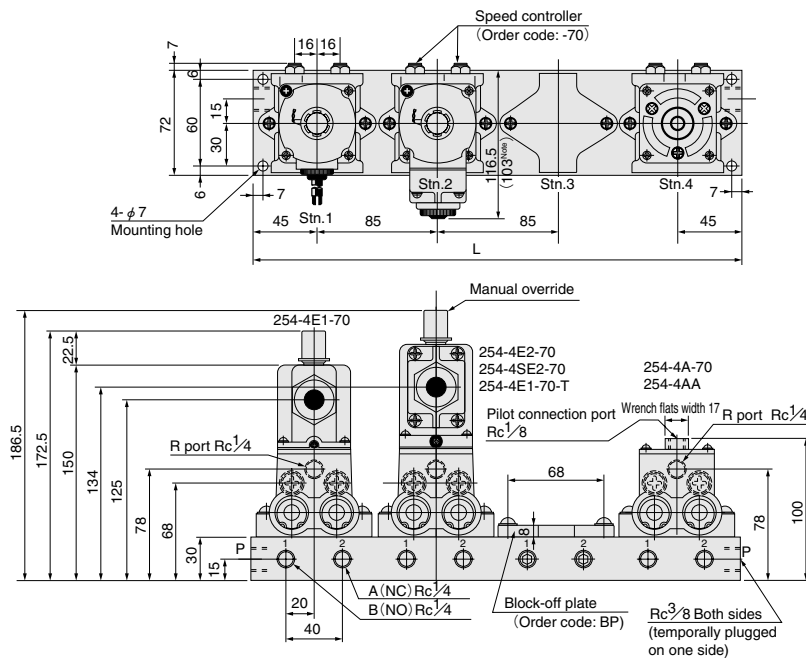

Note: Shows the 254-4E2 and 254-4E1-T dimensions.

Manifold Mass (with valves)

Manifold model	Mounting valve model	Solenoid valve			Air-piloted valve
		Single solenoid	Double solenoid	Keep solenoid	M254-4A
		M254-4E1	M254-4E2	M254-4SE2	M254-4AA
M2		2.8 [6.2]	3.3 [7.3]	3.1 [6.8]	2.2 [4.9]
M3		4.2 [9.3]	4.9 [10.8]	4.6 [10.1]	3.3 [7.3]
M4		5.6 [12.3]	6.5 [14.3]	6.1 [13.5]	4.4 [9.7]
M5		7.0 [15.4]	8.1 [17.9]	7.6 [16.8]	5.5 [12.1]
M6		8.4 [18.5]	9.7 [21.4]	9.1 [20.1]	6.6 [14.6]
Single valve unit		0.9 [2.0]	1.2 [2.6]	1.1 [2.4]	0.6 [1.3]

Major Parts and Materials

Parts	Materials
Base	Aluminum alloy (anodized)
Block-off plate	Aluminum alloy (anodized)