

KOGANEI

ACCESSORIES GENERAL CATALOG

AIR TREATMENT, AUXILIARY, VACUUM,
AND FLUORORESIN PRODUCTS

CONNECTORS CONTENTS



Specifications, Order Codes, Size Table	385
Dimensions (Standard Type)	386
Dimensions (Mini Type)	387
Safety Precautions, Handling Instructions and Precautions	388
Example of Connection, Features	390

CONNECTORS

CONNECTORS

Standard Type Mini Type

● Use the connector bar to assemble multiple numbers of connectors either horizontally or vertically.

● Combination compatibility enables connections even between units of different sizes.

● Use an Allen wrench or flat blade screwdriver to rotate the pin and lock in place.

Specifications

Media	Air
Maximum operating pressure	0.9MPa [131psi.]
Operating vacuum pressure	-100kPa [-29.54in.Hg]
Operating temperature range	0~60°C [32~140°F]
Recommended tube	Nylon tube, urethane tube
Sales unit	1 pc.

Order Codes

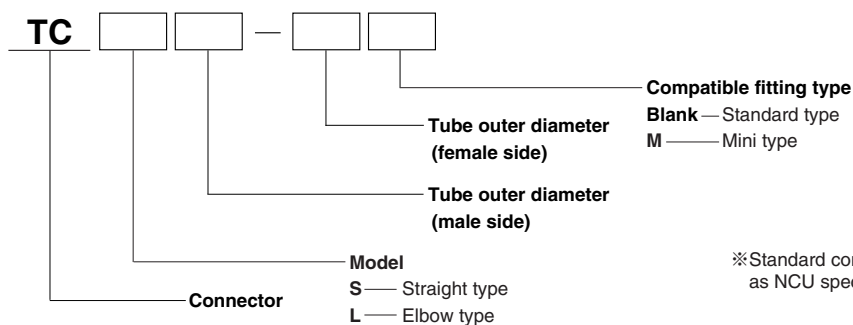

Connector bar
CBT : For vertical joint
CBH : For horizontal joint

※Standard connectors can be used as NCU specification.

● TCS Standard straight 386



Tube size
6-6
6-8
8-8
8-6

● TCL Standard elbow 386



Tube size
6-6
6-8
8-8
8-6

● TCS-M Mini straight 387



Tube size
3-3
3-4
3-6
4-3
4-4
4-6
6-3
6-4
6-6

● TCL-M Mini elbow 387



Tube size
3-3
3-4
3-6
4-3
4-4
4-6
6-3
6-4
6-6

● CBT Connector bar ● CBH 387



● Usable either for standard type or mini type.

Dimensions (Standard Type) (mm)

Straight TCS



Model	Tube outer diameter ϕ D1	Tube outer diameter ϕ D2	B1	B2	B3	L1	L2	C1	C2	F1	F2	J	Effective area (mm ²)	Mass (g) [oz.]
TCS6-6	6	6	54.1	20.8	33.3	29	17	17	17	17.3	19.5	14	10.9	28 [0.99]
TCS6-8		8	54		33.2				18.1	17.2				29 [1.02]
TCS8-6	8	6	54	20.7	33.3	29	17	18.1	17	17.3	19.5	14	10.9	29 [1.02]
TCS8-8		8	53.9		33.2				18.1	17.2				31 [1.09]

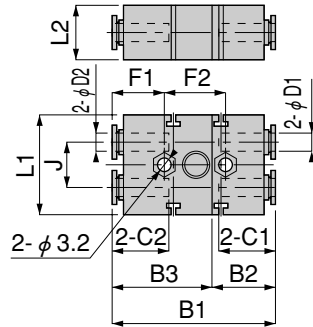

Elbow TCL



Model	Tube outer diameter ϕ D1	Tube outer diameter ϕ D2	B1	B2	B3	L1	L2	C1	C2	H	F	J	Effective area (mm ²)	Mass (g) [oz.]
TCL6-6	6	6	50.3	17	33.3	29	17	17	17	30.3	17.3	14	9.5	31 [1.09]
TCL6-8		8	50.2		33.2				18.1	17.2	9.9		32 [1.13]	
TCL8-6	8	6	50.3	17	33.3	29	17	18.1	17	30.2	17.3	14	10.9	32 [1.13]
TCL8-8		8	50.2		33.2				18.1	17.2	13.3		33 [1.16]	

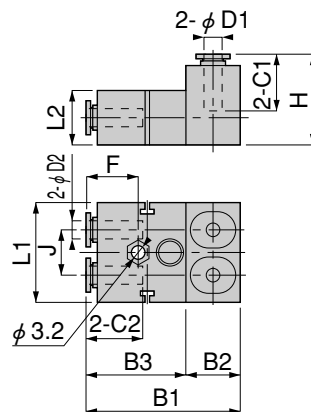

Dimensions (Mini Type) (mm)

Straight TCS-M

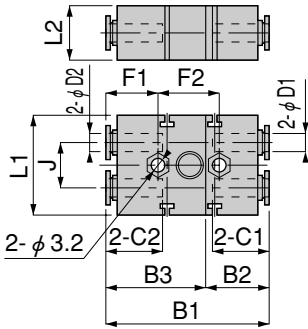

Model	Tube outer diameter ϕ D1	Tube outer diameter ϕ D2	B1	B2	B3	L1	L2	C1	C2	F1	F2	J	Effective area (mm ²)	Mass (g) [oz.]
TCS3-3M	3	3	36.7	14.1	22.6	22	12	11	11	11.8	13.8	10	2.6	11 [0.39]
TCS3-4M		4			23				11.6					
TCS3-6M		6	37.1	11.6	12.2									
TCS4-3M	4	3	36.7	14.1	22.6	22	12	11	11	11.8	13.8	10	2.6	11 [0.39]
TCS4-4M		4			23				11.6				4.2	
TCS4-6M		6	37.1	23	11.6				4.3					
TCS6-3M	6	3	37.1	14.5	22.6	22	12	11.6	11	11.8	13.8	10	2.6	11 [0.39]
TCS6-4M		4			23				11.6				4.2	
TCS6-6M		6	37.5	23	11.6				10.4					

Elbow TCL-M

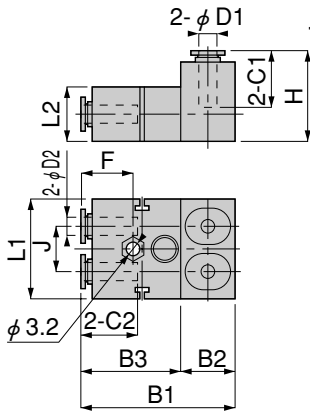

Model	Tube outer diameter ϕ D1	Tube outer diameter ϕ D2	B1	B2	B3	L1	L2	C1	C2	H	F	J	Effective area (mm ²)	Mass (g) [oz.]
TCL3-3M	3	3	34.6	12	22.6	22	12	11	11	20.2	11.8	10	2.3	12 [0.42]
TCL3-4M		4			23				11.6				2.6	
TCL3-6M		6	35	11.6	12.2				3.6					
TCL4-3M	4	3	34.6	12	22.6	22	12	11	11	20.2	11.8	10	2.6	12 [0.42]
TCL4-4M		4			23				11.6				4	
TCL4-6M		6	35	23	11.6				3.6					
TCL6-3M	6	3	34.6	12	22.6	22	12	11.6	11	20.6	11.8	10	2.6	12 [0.42]
TCL6-4M		4			23				11.6				4.2	
TCL6-6M		6	35	23	11.6				8.8	13 [0.46]				

Connector Bar

● For vertical joint CBT

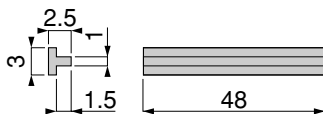

Sales unit : One pack (10 pcs.)

● For horizontal joint CBH

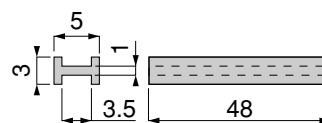

Sales unit : One pack (10 pcs.)

● Connector bars are used for either standard type or mini type.

Model	Mass (g) [oz.]
CBT	0.3 [0.011]
CBH	0.6 [0.021]

Safety Precautions (Connectors)

The following is a safety precaution to Connectors. For other safety precautions, be sure to read the precautions on p.49.

Warning

- With the exception of the Quick Fittings Rotary Type, do not use any quick fittings in locations where thread portions or tubes are subject to swing or rotations. The swing or rotations could result in damage to the fitting body.
- Align the male and female main bodies, push them all the way into each other, and then rotate the lock pin to firmly lock in place. Supplying air while unlocked could cause the two bodies to separate, resulting in personal injury or air leaks.

Caution

- Use a suitable flat blade screwdriver or Allen wrench to rotate the lock pin. An unsuitable tool could result in damage to the lock pin, preventing the main bodies from being disconnected later on.

Handling Instructions and Precautions

● Connection and separation of two main bodies

1. Connection of two main bodies

To connect together and lock in place male and female main bodies, insert a suitable flat blade screwdriver or Allen wrench into the lock pin and rotate 90° in the clockwise direction.

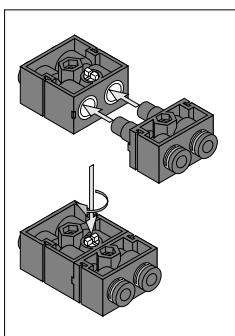

2. Separation of two main bodies

Insert a suitable flat blade screwdriver or an Allen wrench into the lock pin and rotate 90° in the counterclockwise direction to release the lock, and then separate the male and female main bodies.

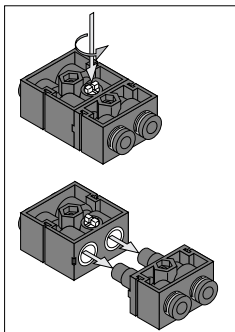

● Tube connection and disconnection

Precautions for connecting the tube

1. Check that the cut section of the tube has been cut at straight angle, that the outer surface of the tube is not scratched, and that the tube has not become oval shaped.
2. When connecting a tube, failure to insert the tube all the way to the end could result in air leaks.

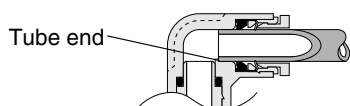

3. After connection, pull the tube to check that it will not disconnect.

Precautions for disconnecting the tube

1. Before disconnecting a tube, check that the pressure inside the tube is down to zero.
2. Push the release ring evenly all the way to the end, and then pull the tube out. An insufficient push could make it impossible to pull the tube out, or could scratch the tube, leaving scratched tube material inside the fitting.

Tube connection and disconnection method

1. Tube connection

The connector (quick fitting section) is equipped with a lock claw that holds the tube in place when it has been pushed all the way to the end, and with an elastic sleeve for sealing the tube periphery.

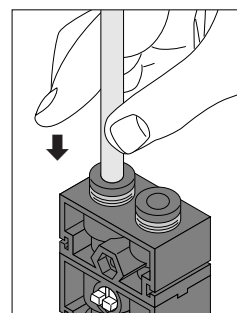

2. Tube disconnection

To disconnect the tube, first push on the release ring, releasing the lock claw, and then pull the tube out. Always stop the air supply before removing the tube.

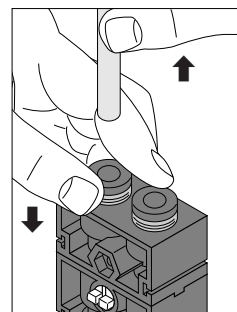

For cases where tight or cramped piping spaces hinder removal tube operations, a special tool is available. Consult us for details.

Special tool for tube removal

For ϕ 3 [0.118in.], ϕ 4 [0.157in.] and ϕ 6 [0.236in.] tubes
Order code : **UJ-1**



For ϕ 6 [0.236in.], ϕ 8 [0.315in.],
 ϕ 10 [0.395in.] and ϕ 12 [0.472in.] tubes
Order code : **UJ-2**



Handling Instructions and Precautions

● Usable tubes

Either nylon or urethane tubes can be used. The tube outer diameter accuracy should be, for nylon tubes, within $\pm 0.1\text{mm}$ [$\pm 0.004\text{in.}$] of the nominal dimensions, and for urethane tubes, within $\pm 0.15\text{mm}$ [$\pm 0.006\text{in.}$] of the nominal dimensions, while the ovalness (difference between long diameter and short diameter) should be within 0.2mm [0.008in.].

- Cautions:**
1. Use tubes with no visible scratches on the outer surface. If a scratch is made during repeated use, cut off the scratched portion.
 2. Do not bend or twist the tube too much near the connection to the fitting. It could result in air leaks. The minimum bending radius for nylon tubes is as shown in the table below.

mm [in.]

Tube size	Minimum bending radius
$\phi 3$ [0.118]	18 [0.7]
$\phi 4$ [0.157]	20 [0.8]
$\phi 6$ [0.236]	30 [1.2]
$\phi 8$ [0.315]	50 [2.0]

Example of Connection

Connect the male and female main bodies, and then lock the lock pin in place by using a flat blade screwdriver or an Allen wrench to rotate the lock pin located at the center of the main body.

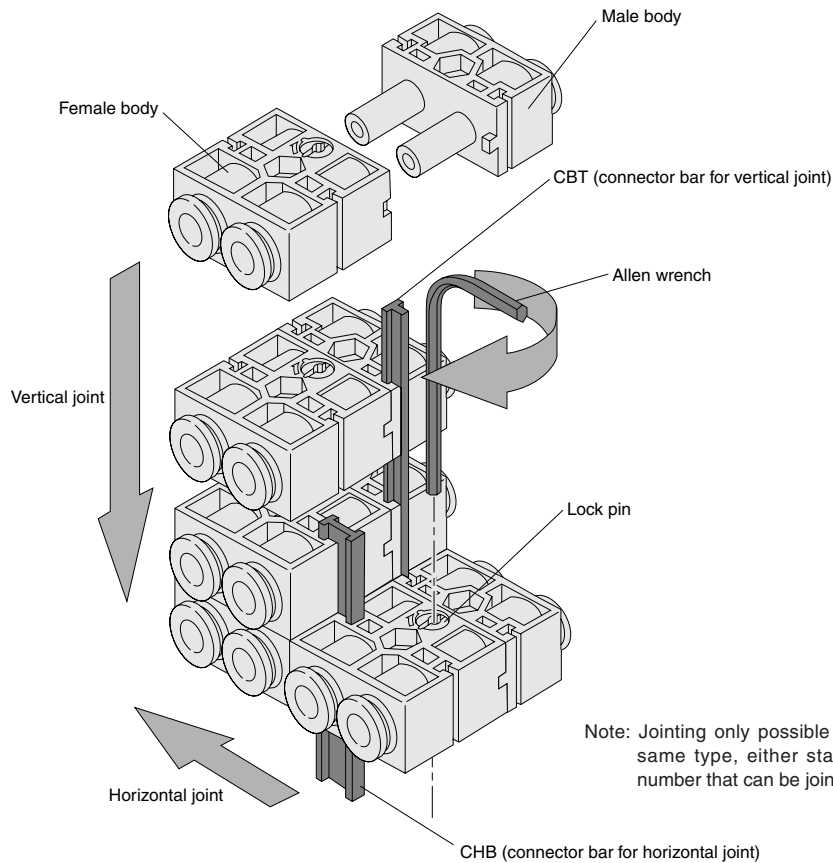

Features

The connector facilitates one-touch connection and disconnection of multiple numbers of piping.

This method allows easy connection, disconnection, and reconfiguration of actuator piping that has been assembled into units.

Piping using the connector

Simple connection and disconnection operations between Unit A and Unit B

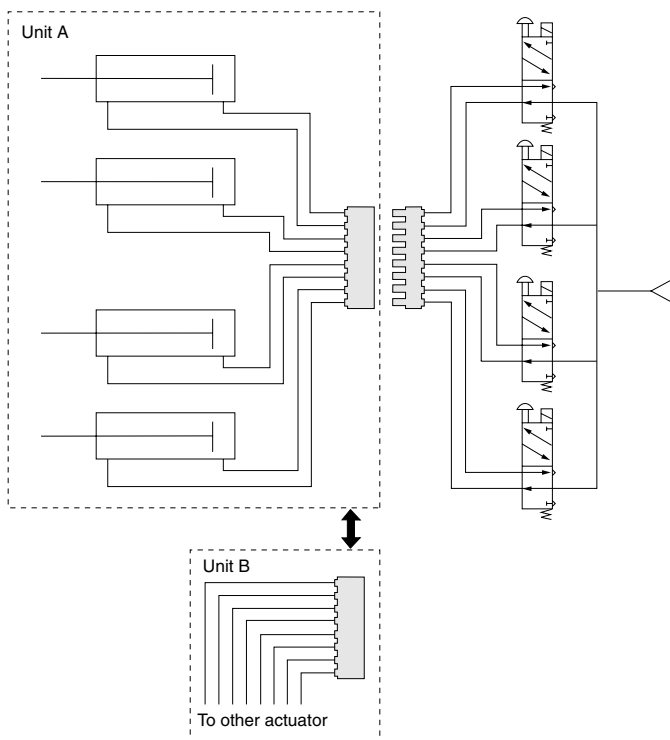

Conventional piping method

