

Product Range

Features (Diaphragm Type)

- **Reliable operation**

Uses diaphragm construction that enables quick and sharp switching peculiar to this type. The valve seat is also reliable.

- **Trouble free structure**

An extremely simple structure and a poppet-type seat method ensures freedom from galling, even if a certain amount of dust intrudes inside.

Moreover, it will not stick even after being left unused for long periods.

- **Can be used without lubrication.**

No sliding parts, and lubrication is unnecessary, and no breakdown problems due to inadequate lubrication.

- **Any mounting direction is acceptable.**

This structure ensures operations without a hitch, no matter what the mounting direction is.

- **Compact and lightweight**

An original compact design, and a light aluminum alloy body.

Manual valves (push button type)

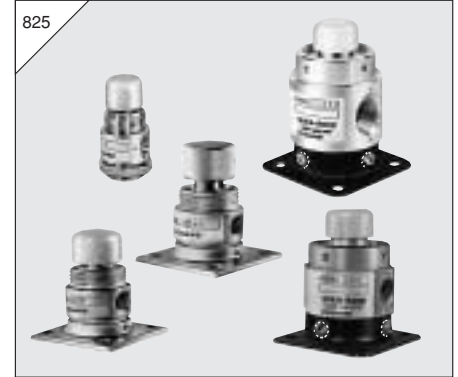

- Using nuts enables compact installation on panels (125P, 125HO types).
- Can also hold the pressed-down condition (125HO type).
- A vacuum valve with a non-leakage structure is also available.

Applications

- ON/OFF for pilot air
- Operation for single acting air cylinders and air grippers
- Filling or exhausting of air tank
- ON/OFF for air supply (125HO)
- ON/OFF for air jet and air blowing

Foot valves

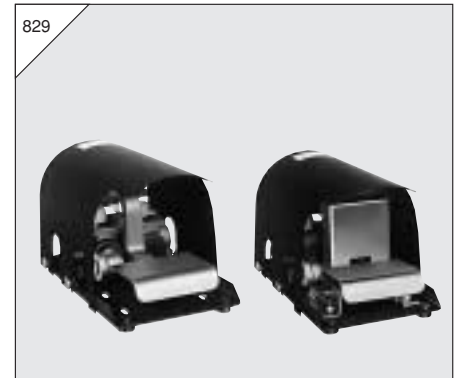

- A holding mechanism maintains the unit in an operating condition, which can then be released by pushing a foot-operated latch located back of the pedal (250FL, 250-4FL, 25034FL).

Applications

- Operation for double acting air cylinders and air grippers
- ON/OFF for pilot air (Double air-piloted valve)

Manual valves (lever-operated type 2-, 3-port)



- Using nuts enables compact installation on panels (125V).
- A vacuum valve with a non-leakage structure is also available.

Applications

- ON/OFF for pilot air
- Operation for single acting air cylinders and air gripper
- Filling or exhausting of air tank
- ON/OFF for air supply
- ON/OFF for air jet and air blowing

Manual valves (lever-operated type 3-position, 5-port)



- Operation of double acting air cylinders and air grippers (In the neutral position, the air cylinder and air gripper are in the free condition, and can be operated manually).
- A vacuum valve with a non-leakage structure is also available.

Applications

- Switching of pilot air
- Switching of air supply

Manual valves



- Sliding valve construction, and manually switched 4-port valve.
- Rotary type (swing lever) for reliable switching.

Applications

- For switching air cylinders

Mechanical valves (ball-cam type)



- Using nuts enables compact installation on panels (125B).
- A vacuum valve with a non-leakage structure is also available.

Applications

- ON/OFF for pilot air
- Operation for single acting air cylinders and air gripper
- Filling or exhausting of air tank
- ON/OFF for air jet and air blowing

Mechanical valves (roller-cam type)

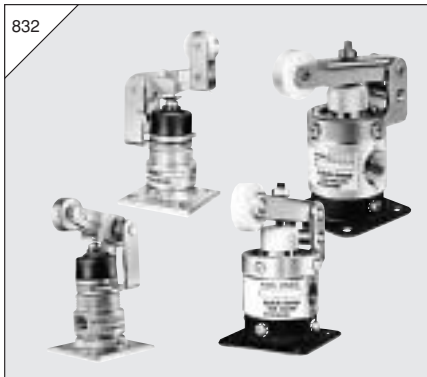

- Sturdy structure capable of withstanding harsh operation. Offers smooth pilot air switching.

Applications

- ON/OFF for pilot air
- Operation for single acting air cylinders and air gripper
- Filling or exhausting of air tank
- ON/OFF for air jet

Micro valves

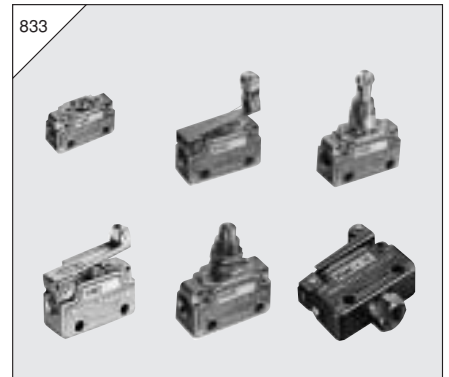

- Both normally closed and normally open types are available for 2-port and 3-port valves, to ensure applications of using every type of pneumatic signal.
- Virtually no change in operational force from low to high pressure range.
- No neutral position means smooth switching between the A port and R port.

Applications

- Confirms operations in pneumatic control circuits.
- Switches air pressure signals.
- Operation of air cylinder
- Filling or exhausting of air tank

MICRO VALVES

Specifications

Port size	Rc1/8 (1(P), 2(A)), 2 holes ϕ 2 (3(R))
Media	Air
Operating pressure range	MPa (kgf/cm ²) [psi.] 0~0.9 {0~9.2} [0~131]
Proof pressure	MPa (kgf/cm ²) [psi.] 1.35 {13.8} [196]
Operating temperature range (atmosphere and media)	°C [°F] 0~60 [32~140]
Effective area	mm ² 1.8
Flow coefficient	Cv 0.08
Valve stroke	mm Approximately 1.5 (For details, see attached table.)
Lubrication	Required (Turbine Oil Class 1 [ISO VG32] is recommended)
Mass	g [oz.] 90 [3.17] (KMP type), 100 [3.53] (KMC type), 130 [4.59] (KMR type)
Options	2-port-2 Normally open-11 With 3(R) port fitting-60
..... Order codes	

Order Codes

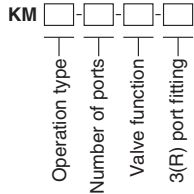

Code	Operation type
P	Pin plunger
C	Roller-cam
O	One way roller-cam
S	Straight plunger
R	Roller plunger

Code	Number of ports
Blank	3
2	2

Code	3(R) port fitting
Blank	—
60	With fitting

Code	Valve function
Blank	NC (normally closed)
11	NO (normally open)

Note : When using as a divider valve, specify as “normally open, and with 3(R) port fitting (-11-60).”
Avoid using the normally closed type as a divider valve.

Flow Rate

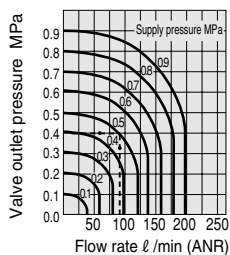

1MPa = 145psi.
1 l/min = 0.0353ft³/min.

How to read the graph

When the supply pressure is 0.5MPa [73psi.] and the flow rate is 85 l/min [3.0ft³/min.] (ANR), the valve outlet pressure becomes 0.4MPa [58psi.].

Time Required for Switching

Model and air-piloted valve position	Switching time
254-4A	Valve: ON (switching air flowing state to 1(P)→4(A)) 0.07 Valve: OFF (switching air flowing state to 1(P)→2(B)) 0.20
375-4A	Valve: ON (switching air flowing state to 1(P)→4(A)) 0.09
501-4A	Valve: OFF (switching air flowing state to 1(P)→2(B)) 0.23
750-4A	Valve: ON (switching air flowing state to 1(P)→4(A)) 0.16 Valve: OFF (switching air flowing state to 1(P)→2(B)) 0.25
1000-4A	Valve: ON (switching air flowing state to 1(P)→4(A)) 0.25
1250-4A	Valve: OFF (switching air flowing state to 1(P)→2(B)) 0.42

Application example

Continuous reciprocating operation of cylinder

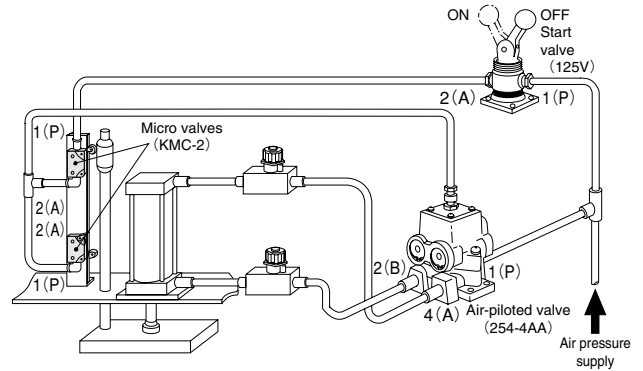

Circuit diagrams

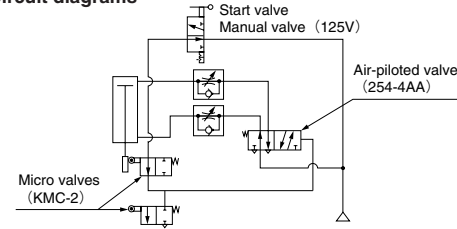

Inner Construction, Major Parts and Materials

3-port, normally closed type (normal condition) 3-port, normally open type (normal condition)

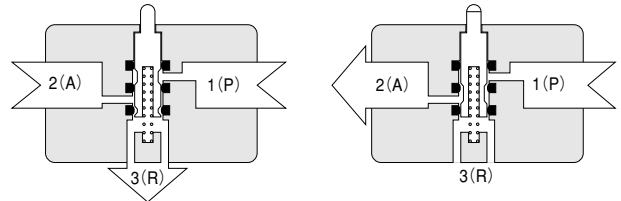

2-port, normally closed type (normal condition)

Construction of straight plunger type

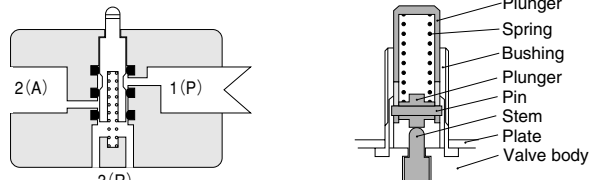

Parts	Materials
Body	Zinc die-casting
Stem	Stainless steel
Seal	Synthetic rubber
O-ring	
Roller	Stainless steel

Model and Valve Stroke

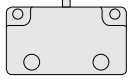
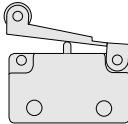
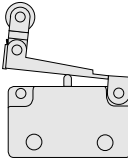
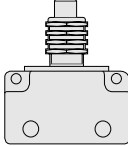
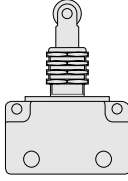
Type	Shape	Model	Function	Operating force N [lbf.] At air pressure 0.9MPa [9.2 kgf/cm ²] [131psi.]	Valve stroke mm [in.]				
					Stroke until actuating	Allowable stroke after actuation	Total stroke		
Pin plunger type		KMP-2	Normally closed (NC)	24.5 [5.51]	1.3 [0.051]	1.2 [0.047]	2.5 [0.098]		
		(KMP-2-11)	Normally open (NO)					0.7 [0.028]	1.8 [0.071]
		KMP	Normally closed (NC)					1.3 [0.051]	1.2 [0.047]
		KMP-11	Normally open (NO)					1.8 [0.071]	0.7 [0.028]
Roller-cam type		KMC-2	Normally closed (NC)	12.8 [2.88]	2.7 [0.106]	2.3 [0.091]	5.0 [0.197]		
		(KMC-2-11)	Normally open (NO)					1.5 [0.059]	3.5 [0.138]
		KMC	Normally closed (NC)					2.7 [0.106]	2.3 [0.091]
		KMC-11	Normally open (NO)					3.8 [0.150]	1.2 [0.047]
One way roller-cam type		KMO-2	Normally closed (NC)	12.8 [2.88]	2.7 [0.106]	2.3 [0.091]	5.0 [0.197]		
		(KMO-2-11)	Normally open (NO)					1.5 [0.059]	3.5 [0.138]
		KMO	Normally closed (NC)					2.7 [0.106]	2.3 [0.091]
		KMO-11	Normally open (NO)					3.8 [0.150]	1.2 [0.047]
Straight plunger type		KMS-2	Normally closed (NC)	24.5 [5.51]	2.0 [0.079]	3.5 [0.138]	5.5 [0.217]		
		(KMS-2-11)	Normally open (NO)					1.0 [0.039]	4.5 [0.177]
		KMS	Normally closed (NC)					2.0 [0.079]	3.5 [0.138]
		KMS-11	Normally open (NO)					3.0 [0.118]	2.5 [0.098]
Roller plunger type		KMR-2	Normally closed (NC)	24.5 [5.51]	2.0 [0.079]	3.5 [0.138]	5.5 [0.217]		
		(KMR-2-11)	Normally open (NO)					1.0 [0.039]	4.5 [0.177]
		KMR	Normally closed (NC)					2.0 [0.079]	3.5 [0.138]
		KMR-11	Normally open (NO)					3.0 [0.118]	2.5 [0.098]

"When the lever is in a horizontal position" it can be used as a guide for full actuation.

Plunger play (Approximately 1mm) is not included.

Notes: 1. Models in parentheses () are made to order items.
 2. The "stroke until actuating" means the movement which occurs from the free position until 1(P)↔2(A) is at the maximum flow rate, for normally closed type 2-, 3-port. And for the normally open type 2-port, it means the stroke which occurs until 1(P)↔2(A) is closed, while for the normally open type 3-port, it means the stroke which occurs until 2(A)↔3(R) is at the maximum flow rate.

Dimensions (mm)

Pin plunger type (basic type)

KMP-2
KMP
KMP-11

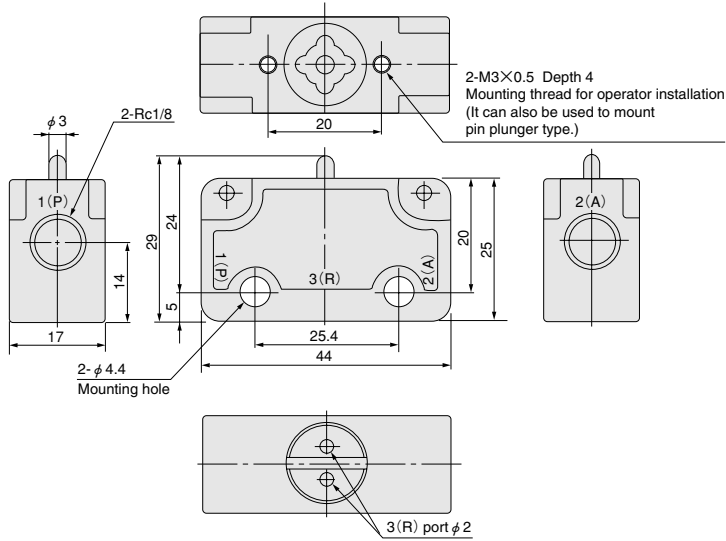

Roller-cam type

KMC-2
KMC
KMC-11

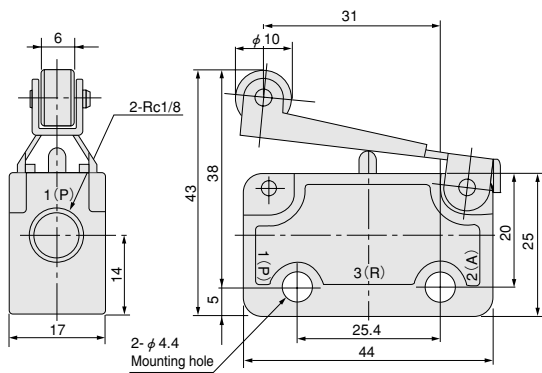

One way roller-cam type

KMO-2
KMO
KMO-11

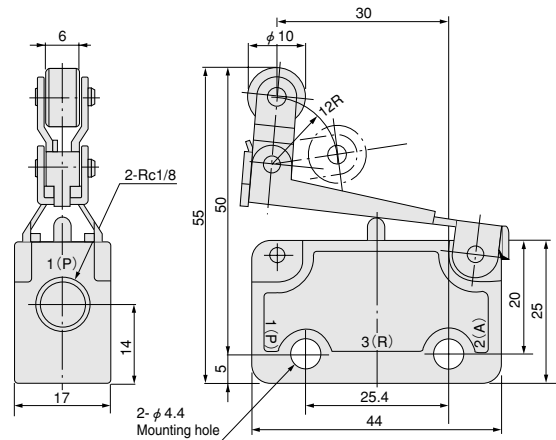

Straight plunger type

KMS-2
KMS
KMS-11

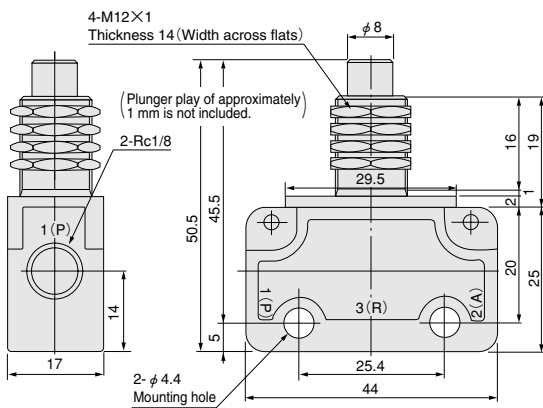

Roller plunger type

KMR-2
KMR
KMR-11

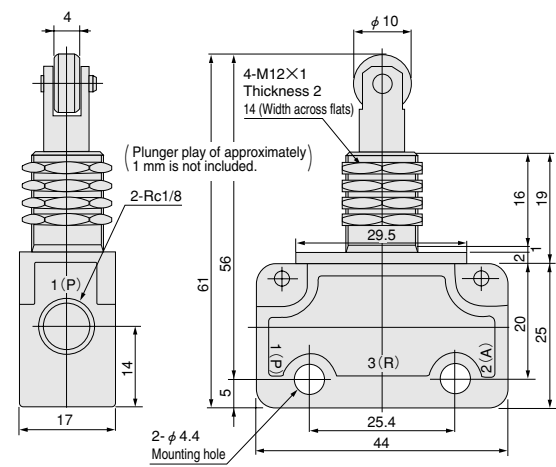

Handling Instructions and Precautions for Micro Valves

Micro valve mounting overview, and cam and dog shapes

- While normal mounting uses 2 mounting holes of $\phi 4.4$ [0.173in.] on the body, use the neck for mounting when not using the roller plunger type in "pushed by load" applications.
- Since the exhaust hole is on the bottom surface of the valve body, leave a clearance of about 1mm [0.04in.] to avoid restricting exhaust.
- Always use the straight plunger type in "pushed by load" applications.
- While the cam and dog shapes normally set θ at about 30° , θ should be set even smaller when the speed reaches 500mm/s [19.7in./sec.] or more.
- For the valve strokes, see the table on p.834.

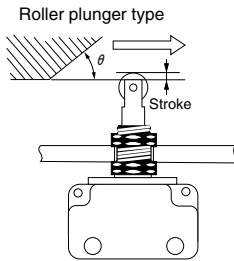
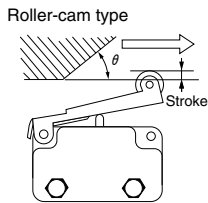

How to use units with exhaust (R) port fittings

For products with a special fitting (Rc1/8) on the 3(R) port, a muffler can be mounted to the 3(R) port, or piping can be connected to exhaust to the outside.

When attaching a muffler on the R port

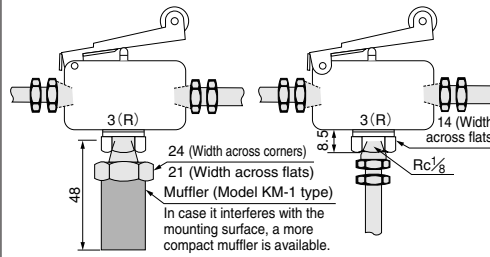

Note: Avoid over-tightening the R port fitting. For piping work, use a wrench to hold the fitting and prevent it from rotating.

When piping on the R port

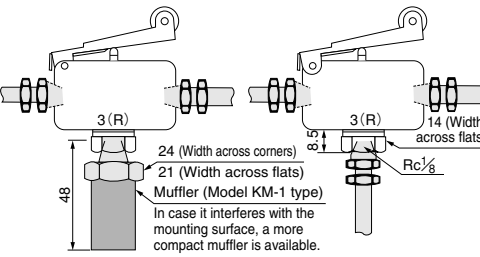

Instructions for cam lever facing changes

The cam acting direction of the roller-cam type (KMC) and one way roller-cam type (KMO) can be changed for use according to the piping requirement.

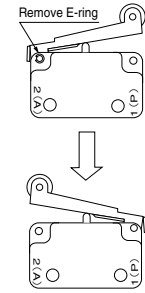

Lubrication

For this micro valve, use Turbine Oil Class 1 (ISO VG32). Depending on the piping conditions (length, height) etc., oil may fail to reach the micro valve. When it occurs, consider supplying turbine oil into the piping at periodic intervals.

How to use as a divider valve

The 3-port, normally open type can be used as a divider valve.

Let air in from the 2(A) port to flow toward the 1(P) port when OFF, and toward the 3(R) port when ON.

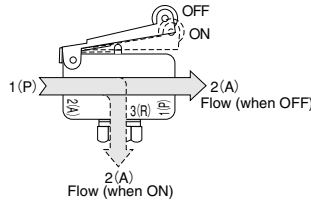

Notes: 1. Avoid using the normally closed type as a divider valve.
2. When using as a divider valve, the Order Code is "-11-60."
Example: Roller-cam type divider valve KMC-11-60

Dust protection

Use appropriate protection when using the micro valve in locations subject to heavy dust, powder, machining chips, etc.

Micro Valve Parts Configuration

The micro valve is composed of the parts shown in the diagram below. The valve functions can differ depending on the shape of the stem, as shown in the diagram.

An identification mark is found on the top of the stem.

