

## Product Range

### Features (Diaphragm Type)

- **Reliable operation**

Uses diaphragm construction that enables quick and sharp switching peculiar to this type. The valve seat is also reliable.

- **Trouble free structure**

An extremely simple structure and a poppet-type seat method ensures freedom from galling, even if a certain amount of dust intrudes inside.

Moreover, it will not stick even after being left unused for long periods.

- **Can be used without lubrication.**

No sliding parts, and lubrication is unnecessary, and no breakdown problems due to inadequate lubrication.

- **Any mounting direction is acceptable.**

This structure ensures operations without a hitch, no matter what the mounting direction is.

- **Compact and lightweight**

An original compact design, and a light aluminum alloy body.

### Manual valves (push button type)

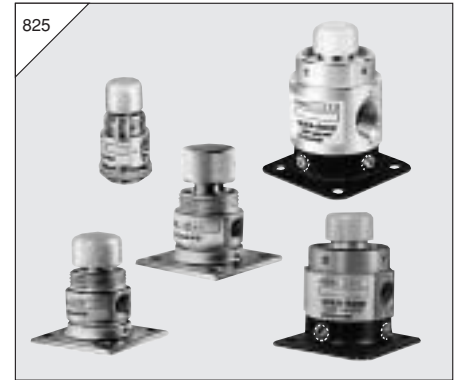

- Using nuts enables compact installation on panels (125P, 125HO types).
- Can also hold the pressed-down condition (125HO type).
- A vacuum valve with a non-leakage structure is also available.

#### Applications

- ON/OFF for pilot air
- Operation for single acting air cylinders and air grippers
- Filling or exhausting of air tank
- ON/OFF for air supply (125HO)
- ON/OFF for air jet and air blowing

### Foot valves

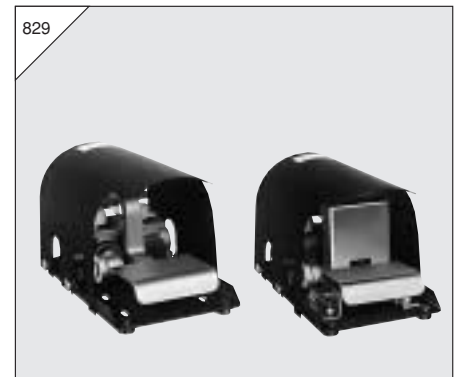

- A holding mechanism maintains the unit in an operating condition, which can then be released by pushing a foot-operated latch located back of the pedal (250FL, 250-4FL, 25034FL).

#### Applications

- Operation for double acting air cylinders and air grippers
- ON/OFF for pilot air (Double air-piloted valve)

**Manual valves  
(lever-operated type 2-, 3-port)**



- Using nuts enables compact installation on panels (125V).
- A vacuum valve with a non-leakage structure is also available.

**Applications**

- ON/OFF for pilot air
- Operation for single acting air cylinders and air gripper
- Filling or exhausting of air tank
- ON/OFF for air supply
- ON/OFF for air jet and air blowing

**Manual valves  
(lever-operated type 3-position, 5-port)**

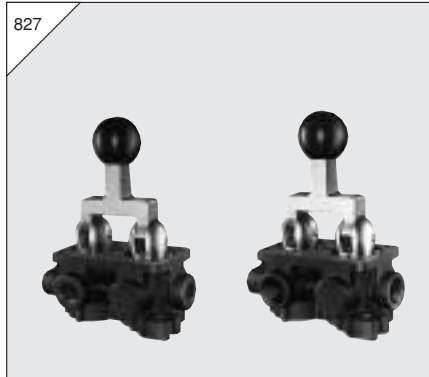

- Operation of double acting air cylinders and air grippers (In the neutral position, the air cylinder and air gripper are in the free condition, and can be operated manually).
- A vacuum valve with a non-leakage structure is also available.

**Applications**

- Switching of pilot air
- Switching of air supply

**Manual valves**



- Sliding valve construction, and manually switched 4-port valve.
- Rotary type (swing lever) for reliable switching.

**Applications**

- For switching air cylinders

**Mechanical valves (ball-cam type)**



- Using nuts enables compact installation on panels (125B).
- A vacuum valve with a non-leakage structure is also available.

**Applications**

- ON/OFF for pilot air
- Operation for single acting air cylinders and air gripper
- Filling or exhausting of air tank
- ON/OFF for air jet and air blowing

**Mechanical valves (roller-cam type)**

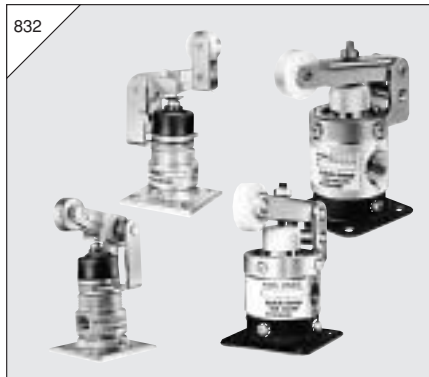

- Sturdy structure capable of withstanding harsh operation.
- Offers smooth pilot air switching.

**Applications**

- ON/OFF for pilot air
- Operation for single acting air cylinders and air gripper
- Filling or exhausting of air tank
- ON/OFF for air jet

**Micro valves**

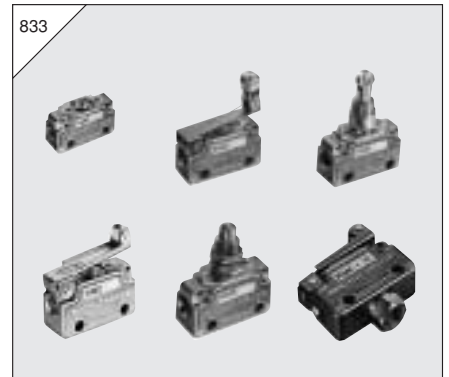

- Both normally closed and normally open types are available for 2-port and 3-port valves, to ensure applications of using every type of pneumatic signal.
- Virtually no change in operational force from low to high pressure range.
- No neutral position means smooth switching between the A port and R port.

**Applications**

- Confirms operations in pneumatic control circuits.
- Switches air pressure signals.
- Operation of air cylinder
- Filling or exhausting of air tank

# MECHANICAL VALVES

## Ball-cam Type

### Symbols

2-port		3-port	
NC (Normally closed)	NO (Normally open)	NC (Normally closed)	NO (Normally open)
125B-2 250B-2 2503B-2	125B-2-11	125B 250B 2503B	125B-11

### Specifications

Item	Basic model	125B	250B	2503B
Port size		Rc1/8	Rc1/4	Rc3/8
Media		Air		
Operating pressure range	MPa [kgf/cm <sup>2</sup> ] [psi.]	0~0.9 [0~9.2] [0~131]		
Proof pressure	MPa [kgf/cm <sup>2</sup> ] [psi.]	1.35 [13.8] [196]		
Operating temperature range (atmosphere and media)	°C [°F]	5~60 [41~140]		
Effective area	mm <sup>2</sup>	5.5	15	
Flow coefficient	Cv	0.27	0.76	
Valve stroke	mm [in.]	0.8 [0.031]	1.6 [0.063]	
Lubrication		Not required		
Mass	kg [lb.]	0.11 [0.24]	0.21 [0.46]	0.26 [0.57]
Options		2-port .....-2 Normally open ...-11 With lock nuts for panel mounting ...-22	2-port .....-2	
	..... Order codes			

### Order Codes

Basic model	Option	Basic model		Option	
		Basic model	Port size	Code	Specifications
125B 250B 2503B	-	125B	Rc1/8	Blank	3-port
		250B	Rc1/4	2	Normally closed 2-port
		2503B	Rc3/8	11	Normally open (125B only)
				22	125B With lock nuts for panel mounting

Examples:  
125B-2-11-22  
250B

### Flow Rate

#### 125 series

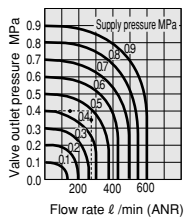

1MPa = 145psi.  
1 l/min = 0.0353ft<sup>3</sup>/min.

#### 250 series 2503 series

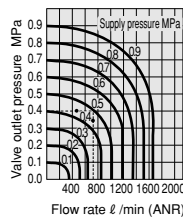

**How to read the graph**  
When the supply pressure is 0.5MPa [73psi.] and the flow rate is 275 l/min [9.71ft<sup>3</sup>/min.] (ANR), the valve outlet pressure becomes 0.4MPa [58psi.].

**How to read the graph**  
When the supply pressure is 0.5MPa [73psi.] and the flow rate is 740 l/min [26.1ft<sup>3</sup>/min.] (ANR), the valve outlet pressure becomes 0.4MPa [58psi.].

### Ball Pushing Down Force

		N [lbf.]				
Model	Main pressure MPa [psi.]	0 [0]	0.2 [29]	0.4 [58]	0.6 [87]	0.8 [116]
125B	Normally closed	16.7 [3.75]	24.5 [5.51]	32.4 [7.28]	40.2 [9.04]	48.1 [10.81]
	Normally open		30.4 [6.83]	50.0 [11.24]	71.6 [16.10]	86.3 [19.40]
250B, 2503B	Normally closed	17.5 [3.93]	36.3 [8.16]	55.9 [12.57]	78.5 [17.65]	104.0 [23.38]

### Inner Construction, Major Parts and Materials

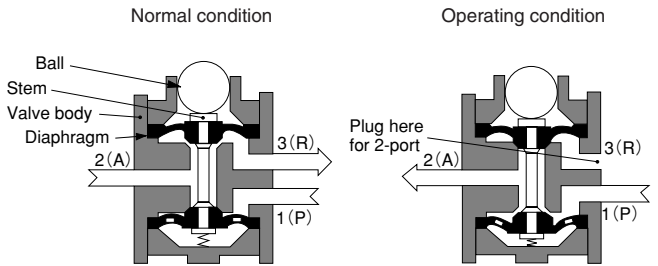

Parts	Materials
Body	Aluminum alloy (anodized)
Stem	Brass
Diaphragm	Synthetic rubber
Ball	Steel

### Dimensions (mm)

#### 125B

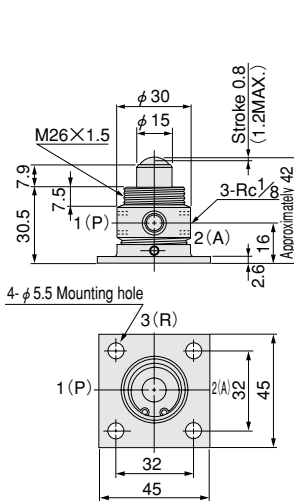

#### 250B 2503B

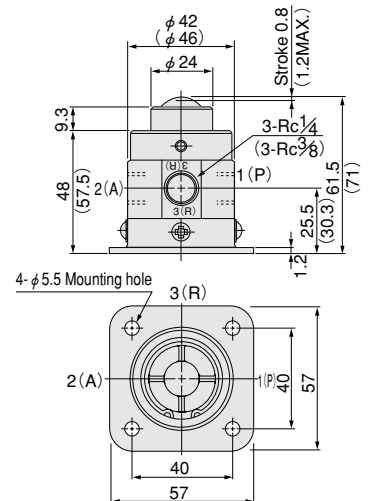

Note: For the normally open type, the exhaust port 3(R) is on the opposite side.