

## Product Range

### Features (Diaphragm Type)

- **Reliable operation**

Uses diaphragm construction that enables quick and sharp switching peculiar to this type. The valve seat is also reliable.

- **Trouble free structure**

An extremely simple structure and a poppet-type seat method ensures freedom from galling, even if a certain amount of dust intrudes inside.

Moreover, it will not stick even after being left unused for long periods.

- **Can be used without lubrication.**

No sliding parts, and lubrication is unnecessary, and no breakdown problems due to inadequate lubrication.

- **Any mounting direction is acceptable.**

This structure ensures operations without a hitch, no matter what the mounting direction is.

- **Compact and lightweight**

An original compact design, and a light aluminum alloy body.

### Manual valves (push button type)

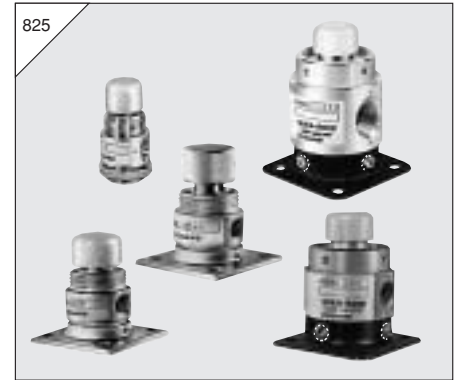

- Using nuts enables compact installation on panels (125P, 125HO types).
- Can also hold the pressed-down condition (125HO type).
- A vacuum valve with a non-leakage structure is also available.

#### Applications

- ON/OFF for pilot air
- Operation for single acting air cylinders and air grippers
- Filling or exhausting of air tank
- ON/OFF for air supply (125HO)
- ON/OFF for air jet and air blowing

### Foot valves

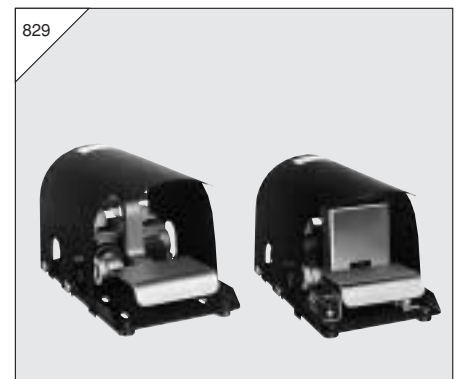

- A holding mechanism maintains the unit in an operating condition, which can then be released by pushing a foot-operated latch located back of the pedal (250FL, 250-4FL, 25034FL).

#### Applications

- Operation for double acting air cylinders and air grippers
- ON/OFF for pilot air (Double air-piloted valve)

**Manual valves  
(lever-operated type 2-, 3-port)**



- Using nuts enables compact installation on panels (125V).
- A vacuum valve with a non-leakage structure is also available.

**Applications**

- ON/OFF for pilot air
- Operation for single acting air cylinders and air gripper
- Filling or exhausting of air tank
- ON/OFF for air supply
- ON/OFF for air jet and air blowing

**Manual valves  
(lever-operated type 3-position, 5-port)**

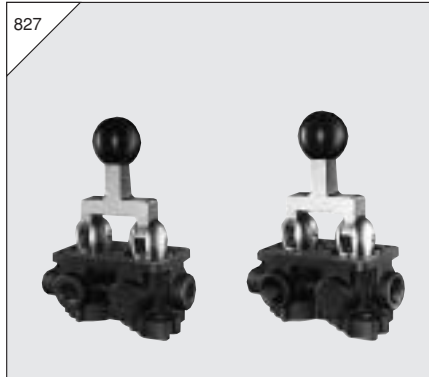

- Operation of double acting air cylinders and air grippers (In the neutral position, the air cylinder and air gripper are in the free condition, and can be operated manually).
- A vacuum valve with a non-leakage structure is also available.

**Applications**

- Switching of pilot air
- Switching of air supply

**Manual valves**



- Sliding valve construction, and manually switched 4-port valve.
- Rotary type (swing lever) for reliable switching.

**Applications**

- For switching air cylinders

**Mechanical valves (ball-cam type)**



- Using nuts enables compact installation on panels (125B).
- A vacuum valve with a non-leakage structure is also available.

**Applications**

- ON/OFF for pilot air
- Operation for single acting air cylinders and air gripper
- Filling or exhausting of air tank
- ON/OFF for air jet and air blowing

**Mechanical valves (roller-cam type)**

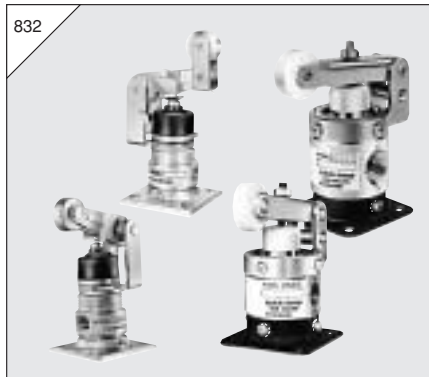

- Sturdy structure capable of withstanding harsh operation.
- Offers smooth pilot air switching.

**Applications**

- ON/OFF for pilot air
- Operation for single acting air cylinders and air gripper
- Filling or exhausting of air tank
- ON/OFF for air jet

**Micro valves**

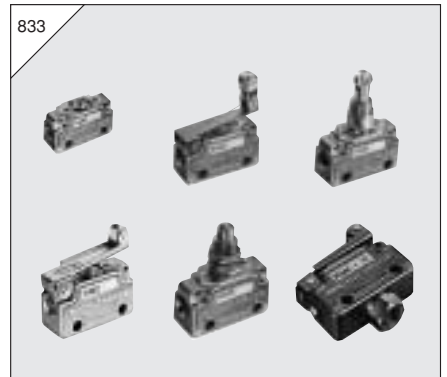

- Both normally closed and normally open types are available for 2-port and 3-port valves, to ensure applications of using every type of pneumatic signal.
- Virtually no change in operational force from low to high pressure range.
- No neutral position means smooth switching between the A port and R port.

**Applications**

- Confirms operations in pneumatic control circuits.
- Switches air pressure signals.
- Operation of air cylinder
- Filling or exhausting of air tank

# MECHANICAL VALVES

## Roller-cam Type

### Symbols

Roller-cam				One way roller-cam			
2-port		3-port		2-port		3-port	
NC (Normally closed)	NO (Normally open)	NC (Normally closed)	NO (Normally open)	NC (Normally closed)	NO (Normally open)	NC (Normally closed)	NO (Normally open)
125MC-2 250C-2 2503C-2	125MC-2-11 250C-2-11 2503C-2-11	125MC 250C 2503C	125MC-11 250C-11 2503C-11	125MOC-2	125MOC-2-11	125MOC	125MOC-11

### Specifications

Item	Basic model	125MC	125MOC	250C	2503C
Operation type		Roller-cam (Steel roller)	One way roller-cam (Steel roller)	Roller-cam (Nylon roller)	
Port size		Rc1/8	Rc1/4	Rc3/8	
Media		Air			
Operating pressure range	MPa [kgf/cm <sup>2</sup> ] [psi.]	0~0.9 [0~9.2] [0~131]			
Proof pressure	MPa [kgf/cm <sup>2</sup> ] [psi.]	1.35 [13.8] [196]			
Operating temperature range (atmosphere and media)	°C [°F]	5~60 [41~140]			
Effective area	mm <sup>2</sup>	5.5	15		
Flow coefficient	Cv	0.27	0.76		
Valve stroke	mm [in.]	0.8 [0.031]	1.6 [0.063]		
Lubrication		Not required			
Mass	kg [lb.]	0.15 [0.33]	0.30 [0.66]	0.35 [0.77]	
Options		2-port .....2 Normally open -11			
Order codes					

### Order Codes

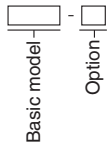

Basic model		Option	
Basic model	Specifications	Code	Specifications
125MC	Rc1/8 Roller-cam	Blank	3-port Normally closed
125MOC	Rc1/8 One way roller-cam	2	2-port
250C	Rc1/4 Roller-cam	11	Normally open
2503C	Rc3/8 Roller-cam		

Examples:  
125MC-2-11  
2503C

### Flow Rate

#### 125 series

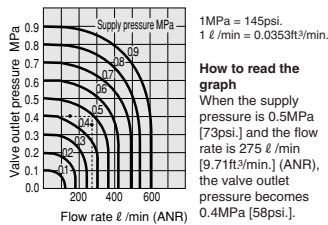

#### 250 series 2503 series

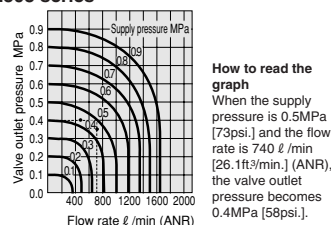

### Roller Pushing Down Force

		N [lbf.]				
Model	Main pressure MPa [psi.]	0 [0]	0.2 [29]	0.4 [58]	0.6 [87]	0.8 [116]
125MC	Normally closed	12.8 [2.88]	15.7 [3.53]	19.6 [4.41]	24.5 [5.51]	29.4 [6.61]
	Normally open		14.7 [3.30]	17.7 [3.98]	22.6 [5.08]	26.5 [5.96]
125MOC	Normally closed	10.8 [2.43]	13.7 [3.08]	18.6 [4.18]	22.6 [5.08]	26.5 [5.96]
	Normally open		12.8 [2.88]	15.7 [3.53]	19.6 [4.41]	23.5 [5.28]
250C	Normally closed	12.8 [2.88]	19.6 [4.41]	28.4 [6.38]	38.3 [8.61]	54.9 [12.34]
2503C	Normally open			24.5 [5.51]	30.4 [6.83]	39.2 [8.81]

### Inner Construction, Major Parts and Materials

#### 125 series Normal condition

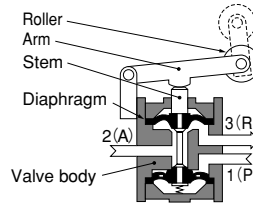

#### 250 series 2503 series Normal condition

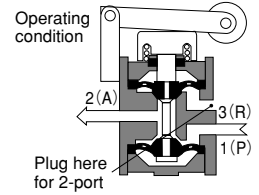
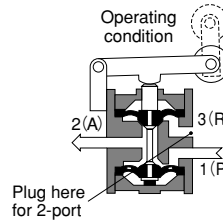
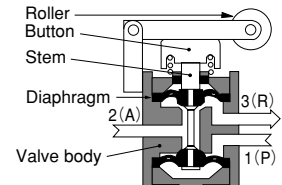

Parts	Materials
Body	Aluminum alloy (anodized)
Stem	Brass
Diaphragm	Synthetic rubber
Roller	125 series: Steel 250, 2503 series: Nylon

### Dimensions (mm)

#### 125MC

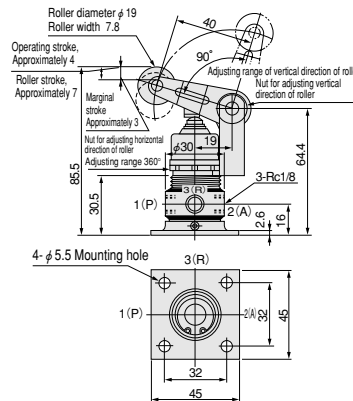

#### 125MOC

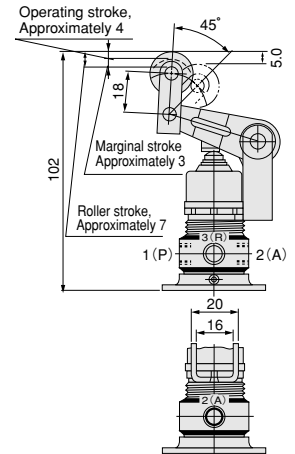

#### 250C 2503C

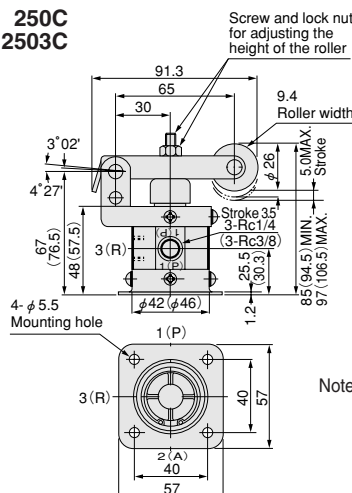

Note: Dimensions not specified are the same as for the 125MC.

Notes: 1. Dimensions in parentheses ( ) are for the 2503C.  
2. For the normally open type, the exhaust port 3(R) is on the opposite side.