

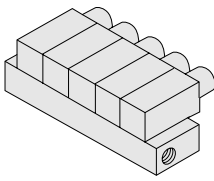

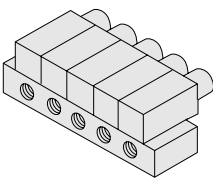

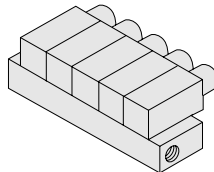
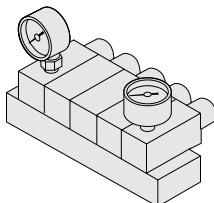

Flexible and centralized control of supply pressure

Manifold Regulators

The Manifold Regulator offers adjustment and confirmation of supply pressure at a single location. Moreover, a new high-relief type has been added to the R100 series, further expanding functional capabilities. P port piping is available in two types, a port collective type and an individual station type, selected according to flow rate and primary pressure conditions.

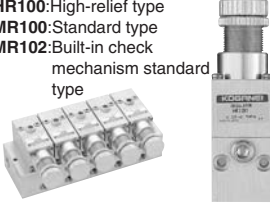
In addition, such options as the built-in check mechanism type, the compact pressure gauge, as well as the non-ion specification, offer flexible response to every application.

		A type manifold: P port collective type	B type manifold: P port individual station type	Mounting regulator	Option: Pressure gauge
Basic models and configurations of manifold regulators ●The high-relief type manifold (R100M□H□) can be mounted in combination with the standard regulator. ●The standard type regulator is also a relief type.					
R050 series		R050M□A	R050M□B	MR050:Standard type MR052:Built-in check mechanism standard type 	
R100 series	Standard type	R100M□A	R100M□B	MR100:Standard type MR102:Built-in check mechanism standard type 	-GA:Bottom piping $\phi 20 \times 1 \text{MPa}$ (Order code for the pressure gauge only: G1-20A) 
	High-relief type	R100M□HA	R100M□HB	HR100:High-relief type MR100:Standard type MR102:Built-in check mechanism standard type 	-GD:Back piping $\phi 20 \times 1 \text{MPa}$ (Order code for the pressure gauge only: G1-20D) 

Flow Rate Characteristics

MR050

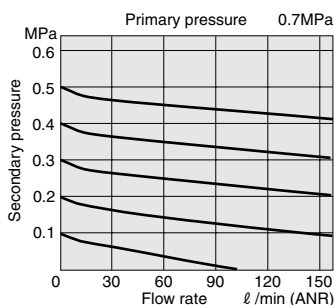

MR100

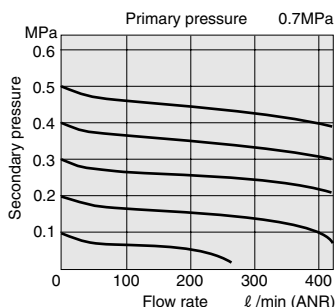

HR100

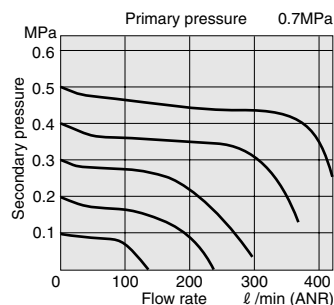

1MPa = 145psi.
1 l/min = 0.0353ft³/min.

Symbols

Standard type

P port collective type: **R050M□A, R100M□A**

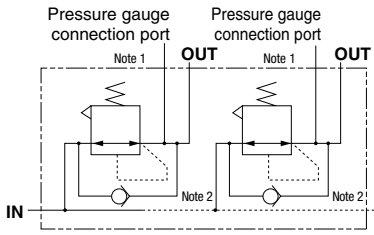

Notes: 1. The R050 series does not have a pressure gauge connection port.
2. The check mechanism is available in MR052 and MR102 only.

Individual station type: **R050M□B, R100M□B**

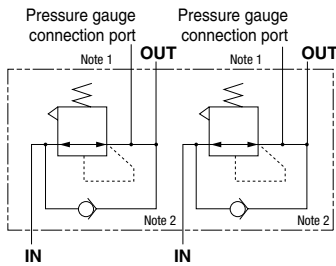

Notes: 1. The R050 series does not have a pressure gauge connection port.
2. The check mechanism is available in MR052 and MR102 only.

High-relief type

P port collective type: **R100M□HA**

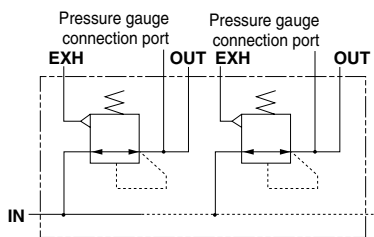

Individual station type: **R100M□HB**

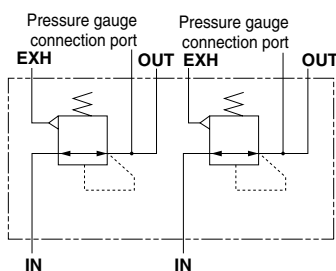

Specifications

Model	Standard type	MR050	MR100	—
	Built-in check mechanism	MR052	MR102	—
	High-relief type	—	—	HR100
Item				
Media	Air			
Operation method	Piston type	Diaphragm type	Piston type	
Port size ^{Note}	Rc	1/8	1/8, 1/4	
Pressure setting range	MPa [psi.]	0.05~0.5 [7~73]	0.05~0.7 [7~102]	
Relief starting pressure	MPa [psi.]	—	—	Setting pressure +0.03 [4]
Maximum operating pressure	MPa [psi.]	0.7 [102]	0.9 [131]	0.93 [135]
Proof pressure	MPa [psi.]	1.03 [149]	1.32 [191]	1.47 [213]
Operating temperature range	°C [°F]	5~60 [41~140]		
Options	Pressure gauge	—	With G1-20A (bottom piping) or G1-20D (back piping)	

Note: See the table of port size, for details

Port size

Model	Ports	Location of piping connection	Port size
R050M□A	IN	Manifold (collective)	Rc1/8
	OUT	Manifold	
R050M□B	IN	Manifold	Rc1/8
	OUT	Manifold	
R100M□A	IN	Manifold (collective)	Rc1/4
	OUT	Manifold	Rc1/8
R100M□B	Pressure gauge connection port	Regulator body	Rc1/8
	IN	Manifold	
	OUT	Manifold	
R100M□HA	Pressure gauge connection port	Regulator body	Rc1/8
	IN	Manifold (collective)	
	OUT	Manifold	
R100M□HB	Pressure gauge connection port	Regulator body	Rc1/8
	IN	Manifold	
	OUT	Manifold	
	EXH (relief)	Manifold	

Mass

Model	Manifold mass calculation (n=No. of units)	Mounted regulator			Pressure gauge (Optional)		Block-off plate
		MR050 MR052	MR100 MR102	HR100	-GA20	-GD20	
R050M□A, R050M□B	$\frac{(24 \times n) + 20}{[0.053 \times n + 0.044]}$	40 [0.088]	—	—	—	—	3 [0.007]
R100M□A, R100M□B	$\frac{(36 \times n) + 30}{[0.079 \times n + 0.066]}$	—	82 [0.181]	—	37 [0.082]	33 [0.073]	5 [0.011]
R100M□HA, R100M□HB	$\frac{(124 \times n) + 102}{[0.273 \times n + 0.225]}$	—	82 [0.181]	134 [0.295]	37 [0.082]	33 [0.073]	10 [0.022]

Relief Flow Rate Characteristics

HR100

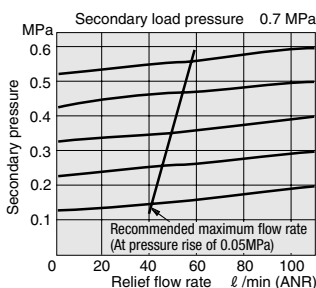

Pressure Characteristics

MR050

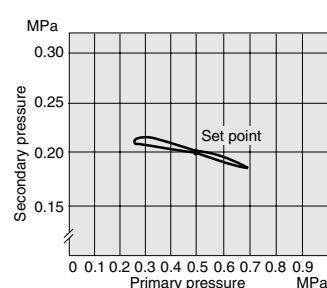

MR100

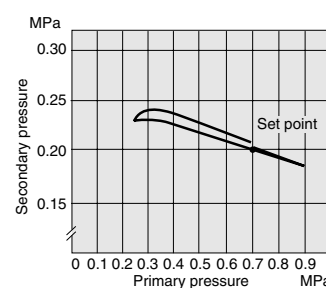

HR100

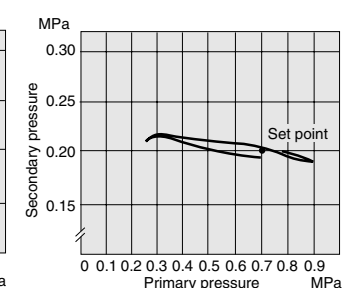

1MPa = 145psi. 1 l/min = 0.0353ft³/min.

Inner Construction

- MR050
- MR052

- MR100
- MR102

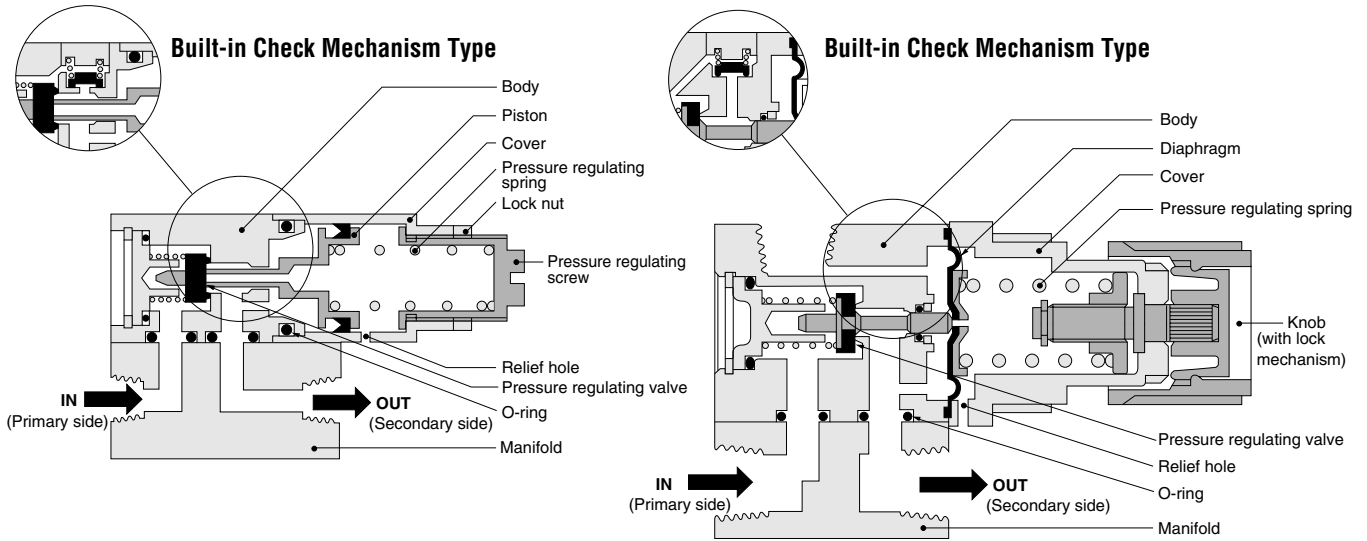

- HR100

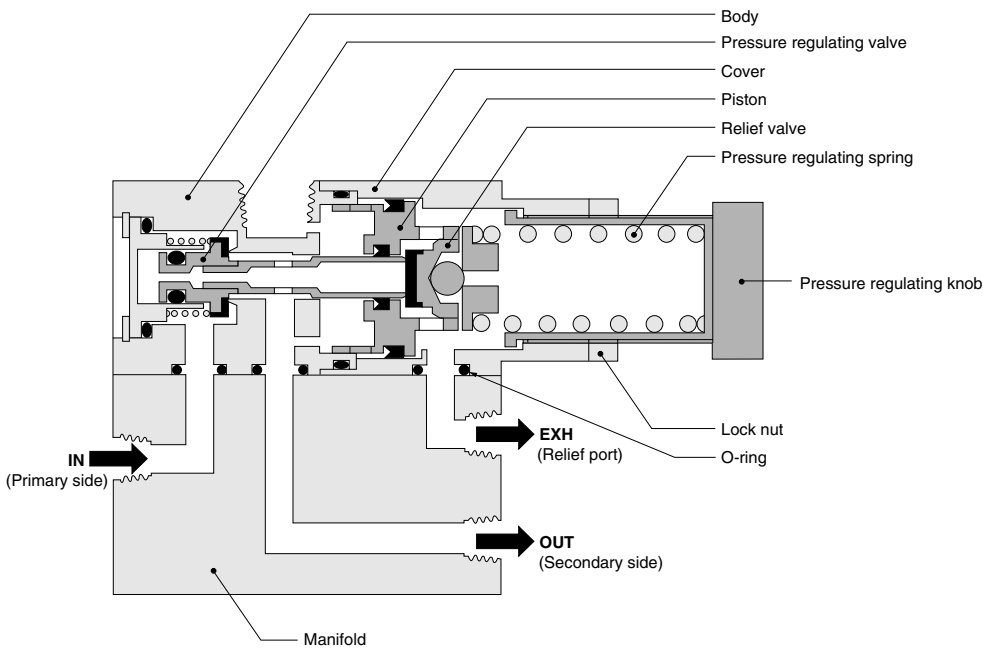

Major Parts and Materials

Item	Model	MR050	MR100	HR100	Non-ion specification
Body		Aluminum alloy (anodized)	Aluminum die-casting	Aluminum alloy (anodized)	←
Pressure regulating screw		Brass	—	—	Brass (Electroless nickel plated)
Knob		—	Plastic (POM)	—	←
Pressure regulating knob		—	—	Aluminum alloy (anodized)	←
Cover		Aluminum alloy (anodized)	—	Brass	Brass (Electroless nickel plated)
Bonnet		—	Plastic (PBT)	—	←
Piston		Aluminum alloy (anodized)	—	Aluminum alloy (anodized)	←
Diaphragm		—	Synthetic rubber (NBR)	—	←
Pressure regulating spring		—	Piano wire (chromated)	—	←
Seal		—	Synthetic rubber (NBR)	—	←
Pressure regulating valve assembly		—	—	Brass	Aluminum alloy, brass (Electroless nickel plated)
Manifold	Body	Aluminum alloy (anodized)			←
	Seal	Synthetic rubber (NBR)			←

Remark: The non-ion specification is made to order.

Order Codes

● Order codes for manifold regulators

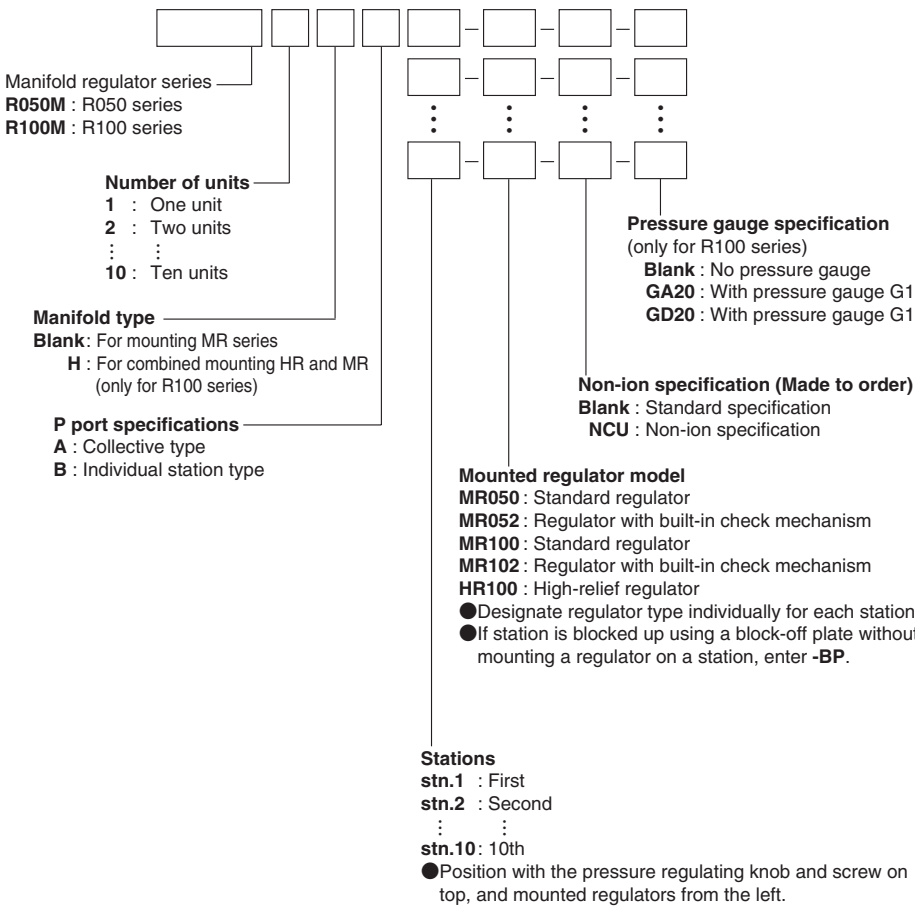

● Order codes for regulator only

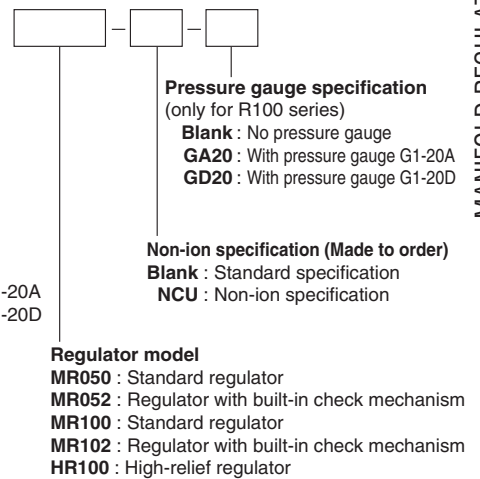

● Order codes for pressure gauges only

- G1-20A** : A type (bottom piping, $\phi 20 \times 1\text{MPa}$ [145psi.])
- G1-20D** : D type (back piping, $\phi 20 \times 1\text{MPa}$ [145psi.])

● Order codes for block-off plates only

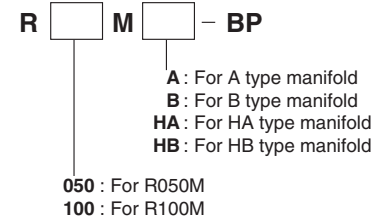

Application Examples

● When using standard types with built-in check mechanism (MR052, MR102)

● Differential pressure operation

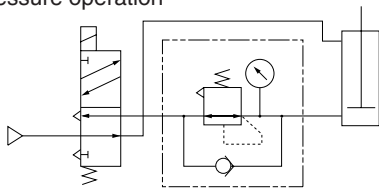

● Speed control

Usable only with cylinders with bore size of 32mm [1.26in.] and 40mm [1.57in.] equivalent.

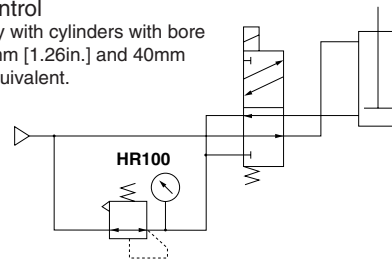

● High-relief type (HR100)

For one HR100 unit, use a cylinder with bore size of 32mm and stroke of 200mm or less.

● Balancer, tension control, or compressed pressure control

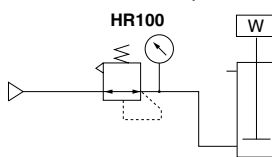

● Differential pressure operation

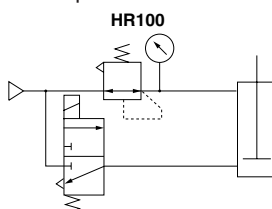

● Rapid speed control

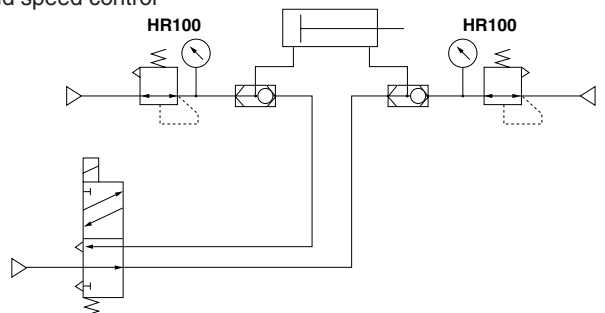

Note: As the high-relief type HR100 has a relief starting pressure of about 0.03MPa [4psi.], it cannot be used for high-precision control.

Dimensions (mm)

- R050M□A
- R050M□B

Unit dimensions

Model	P	L
R050M1A, R050M1B	28	36
R050M2A, R050M2B	47	55
R050M3A, R050M3B	66	74
R050M4A, R050M4B	85	93
R050M5A, R050M5B	104	112
R050M6A, R050M6B	123	131
R050M7A, R050M7B	142	150
R050M8A, R050M8B	161	169
R050M9A, R050M9B	180	188
R050M10A, R050M10B	199	207

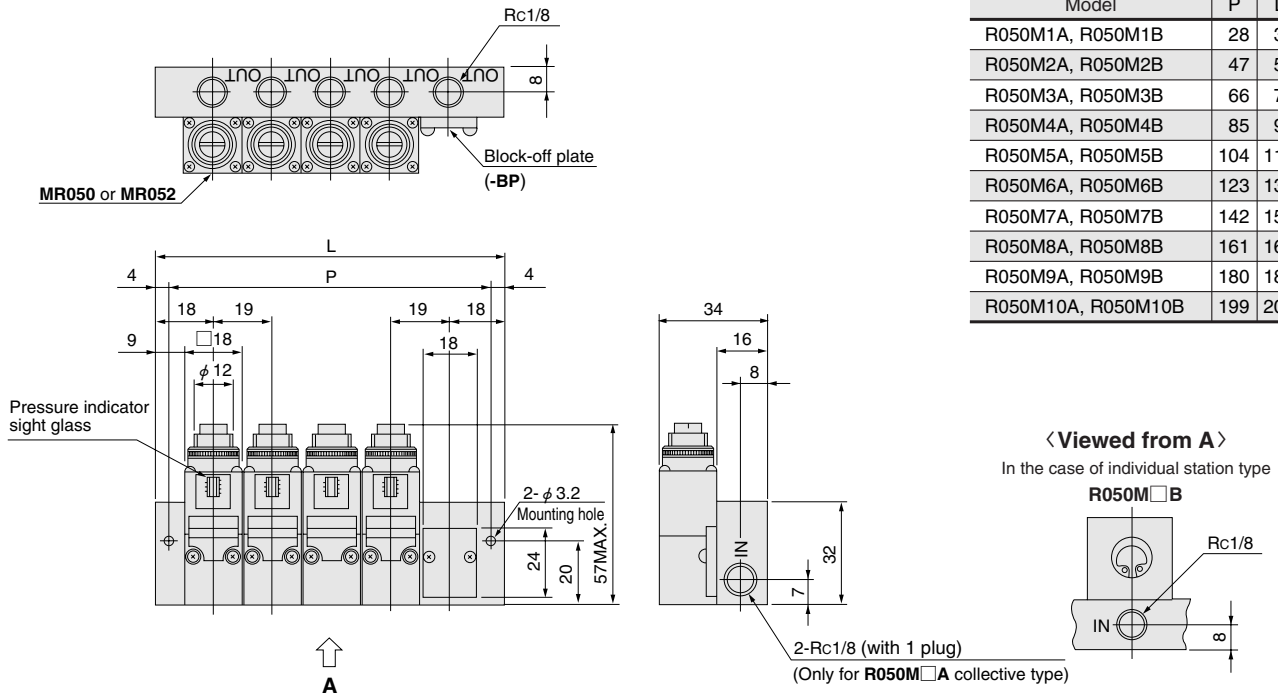

- R100M□A
- R100M□B

Unit dimensions

Model	P	L
R100M1A, R100M1B	42	50
R100M2A, R100M2B	70	78
R100M3A, R100M3B	98	106
R100M4A, R100M4B	126	134
R100M5A, R100M5B	154	162
R100M6A, R100M6B	182	190
R100M7A, R100M7B	210	218
R100M8A, R100M8B	238	246
R100M9A, R100M9B	266	274
R100M10A, R100M10B	294	302

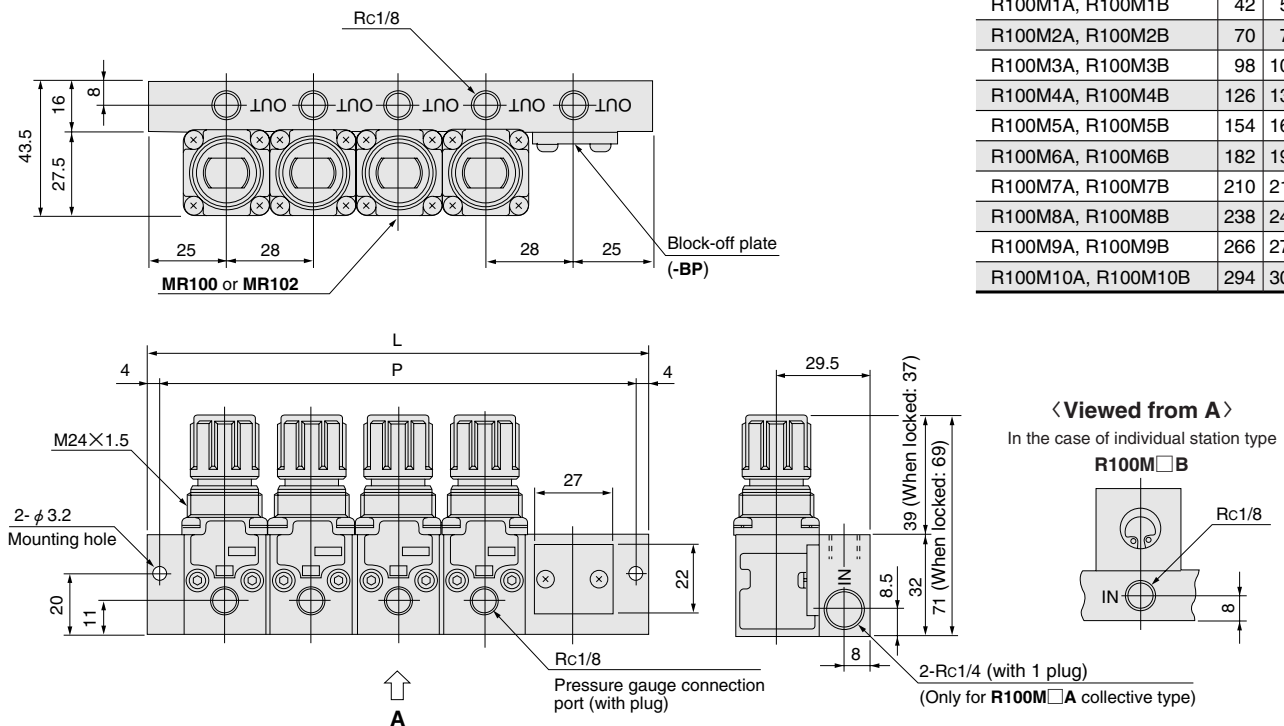

- R100M□HA
- R100M□HB

Unit dimensions

Model	P	L
R100M1HA, R100M1HB	42	50
R100M2HA, R100M2HB	70	78
R100M3HA, R100M3HB	98	106
R100M4HA, R100M4HB	126	134
R100M5HA, R100M5HB	154	162
R100M6HA, R100M6HB	182	190
R100M7HA, R100M7HB	210	218
R100M8HA, R100M8HB	238	246
R100M9HA, R100M9HB	266	274
R100M10HA, R100M10HB	294	302

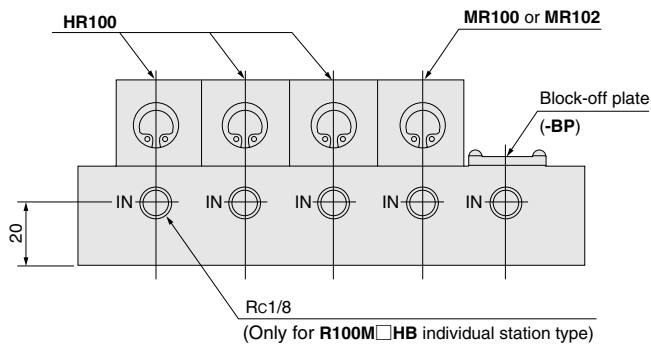
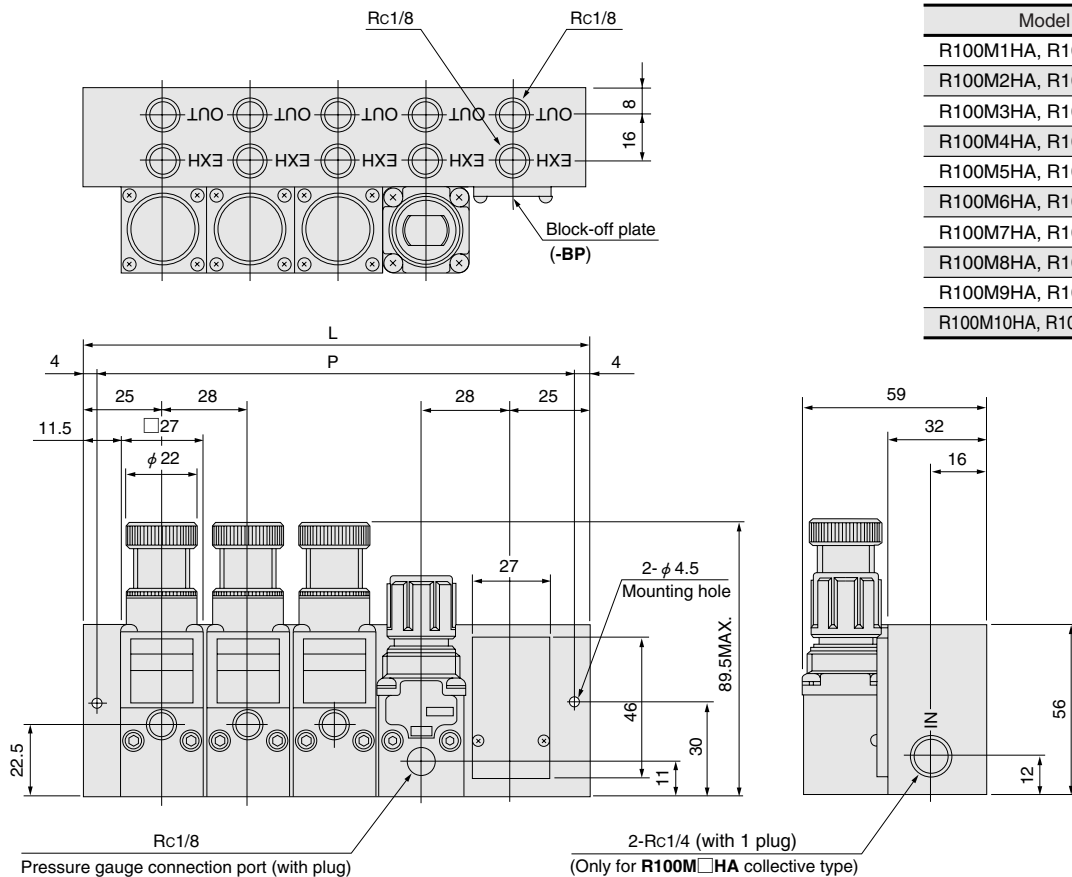

● **Pressure gauge**
G1-20A

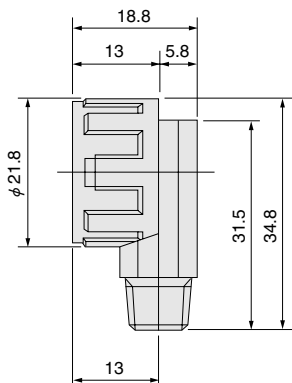
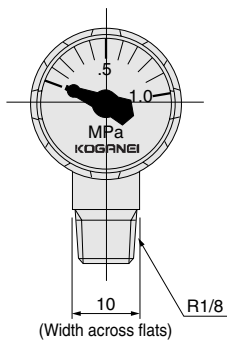

G1-20D

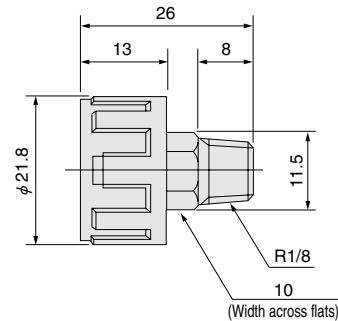
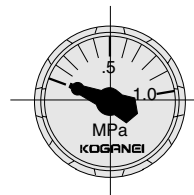

Remark: The compact pressure gauge uses a spiral Bourdon tube. A number of scale plates are provided to compensate for the precision of the spiral Bourdon tube. Comparison of two or more scale plates creates a scale angle difference from 0° to 45°.

Handling Instructions and Precautions



Pressure regulating

1. Install a pressure gauge to regulate pressure. In the R050 series, there is a pressure indicator sight glass. Use it to measure as a guide.
2. To regulate the pressure in the MR100 and MR102, pull out the knob firmly. Turning it to the right (clockwise) to increase the pressure, and to the left (counterclockwise) to reduce the pressure. After regulating pressure, push the knob back into the body and lock it in place.

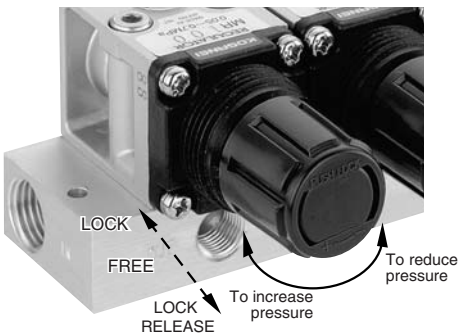

Caution: The high-relief type HR100 has a relief starting pressure of about 0.03MPa [4psi.], this prevents use for high-precision control.

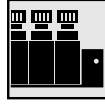

Manifold

Piping

1. Always thoroughly blow off (use compressed air) the piping before connecting it to the valve. Entering chips, sealing tape, rust, etc., generated during piping work could result in air leaks or other defective operation.
2. When using the P port collective type, use P port piping of sufficiently large size, and supply air from the P ports on both sides as much as possible.
3. The high-relief type cannot use the R (relief) port under choked conditions. Also, if installing piping or a muffler, keep the exhaust resistance as low as possible. For the R (relief) port piping, use a tube of at least $\phi 6 \times 4$ (when collective exhaust for two or more units, then $\phi 10 \times 8$ or larger). Use a tube as short as possible. Avoid using a tube of length 2m [6.6ft.] or more.

Caution: When mounting the pressure gauge, use a wrench to tighten the hexagonal portion of the piping connection port, and avoid applying any force to the gauge.

Block-off plate

Use a block-off plate (Order Code: **R050M□-BP**, **R100M□-BP**) to block the stations that are not being used.



General precautions

Media

1. Use air for the media. For the use of any other media, consult us.
2. Use clean air that does not contain deteriorated compressor oil or other contaminants. Install an air filter (with filtration of a minimum $40\mu\text{m}$) close to the valve to eliminate any airborne collected liquid or dust. Moreover, clean the air filter at regular intervals.

Lubrication

While the system can be used without lubrication, if lubricating the actuators etc. is required, use Turbine Oil Class 1 (ISO VG32) or equivalent. Avoid using spindle oil or machine oil.

Atmosphere

1. The product cannot be used when the media or the ambient atmosphere contains any of the substances listed below. Solvents, phosphate ester type hydraulic oil, sulphur dioxide, chlorine gas, or acids, etc.
2. If using in locations subject to dripping water or oil, etc., or to large amounts of dust, use something to cover and protect the unit.

System Upgrade Using a Regulator with Built-In Check Mechanism

The regulator with built-in check mechanism is equipped with a built-in check valve that opens when the primary pressure falls off, causing the pressure balance to break and simultaneously opening the main valve to relieve the secondary pressure to the primary side.

Changing push side and pull side thrust

The thrust on an air cylinder's push side and pull side can be changed easily. Cylinders can be operated at low pressure on the side where thrust is not required, allowing reduction of air consumption.

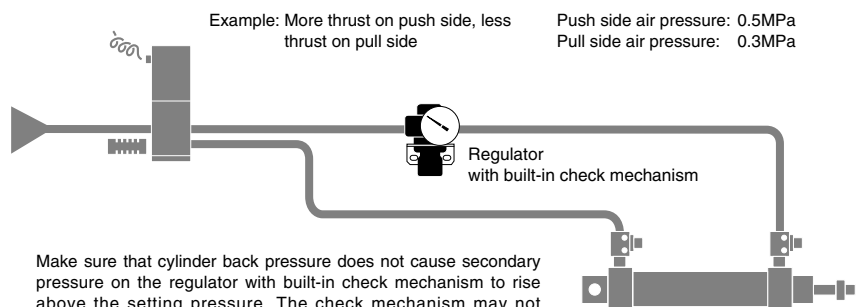

Make sure that cylinder back pressure does not cause secondary pressure on the regulator with built-in check mechanism to rise above the setting pressure. The check mechanism may not operate correctly. (As a guide, use at a pressure differential between the push and pull sides of 0.3MPa or less.)