

**One stroke provides two motions, linear and swing,
expanding the versatility of air cylinders.**

TWIST CYLINDERS

● Medium Load Type RHDA

Allowable moment

- φ 16 [0.630in.] : 5.3N·m [3.9ft·lbf]
- φ 25 [0.984in.] : 14.8N·m [10.9ft·lbf]
- φ 40 [1.575in.] : 52.5N·m [38.7ft·lbf]



● Slim Body and Concentrated Piping for Space Efficiency

Two piping ports on the cylinder head concentrate the piping to save space around the cylinder.



● Various Mounting Types Back Up Design Flexibility

Mounting methods include a nose mount directly secured on the rod cover, and a foot mount using an optional body mounting bracket.

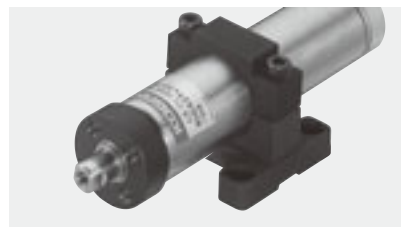

Twist Cylinder Selection Procedure

To use Twist Cylinders, compute the following 3 values (conditions).

Make concrete calculations to confirm whether the values (conditions) are satisfied.

1. Allowable bending moment
2. Allowable kinetic energy
3. Output torque

1. Allowable bending moment

Select a type such that the bending moment on the rod end does not exceed the values listed below.

Allowable bending moment (N·m) $\geq F$ (N) $\times \ell$ (m)

N·m [ft·lbf]	
Bore size mm [in.]	Medium load type (RHDA)
16 [0.630]	5.3 [3.9]
25 [0.984]	14.8 [10.9]
40 [1.575]	52.5 [38.7]

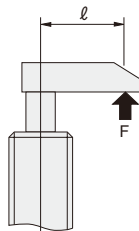

Note : When a Koganei adjusting plate is used for operation, the maximum operating pressure at ϕ 16 [0.630in.] is 0.5MPa [73psi.].

2. Allowable kinetic energy

Kinetic energy is generated when a workpiece and a plate are mounted onto the rod end of the Twist cylinder and rotated. Use Twist cylinders at or below the allowable kinetic energy.

First, calculate the kinetic energy.

Kinetic energy $E = \frac{1}{2} J \omega^2$

E = Kinetic energy (J)
 J = Mass moment of inertia (kg·m²)
 ω = Average angular velocity (rad/s)

Calculation for mass moment of inertia J

The shape is assumed to be as follows.

$J = \frac{m \ell^2}{3}$

ℓ = Distance from rotation center to workpiece end (m)
 m = Mass (kg)

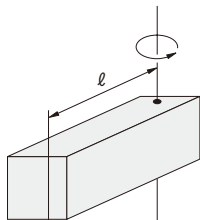

Kinetic energy $E' = \frac{1}{2} J' \omega^2$

E' = Kinetic energy [ft·lbf]
 J' = Mass moment of inertia [lbf·ft·sec²]
 ω = Average angular velocity [rad/sec.]

Calculation for mass moment of inertia J'

The shape is assumed to be as follows.

$J' = \frac{w' \ell'^2}{3g}$

ℓ' = Distance from rotation center to workpiece end [ft.]
 w' = Weight [lbf.]
 g = Acceleration of gravity = 32.2 [ft./sec.²]

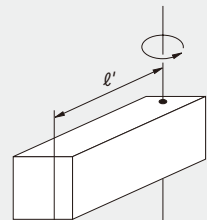

Twist Cylinder Selection Procedure

Calculation of average angular velocity ω

$$\omega = \frac{\theta}{t}$$

θ = Swing angle (rad)
Twist cylinder is 1.57rad.
 $\theta = 1.57(\text{rad})$

t = Swing time (s)
Shows the time required for the Twist cylinder's total stroke operation^{Note} to rotate by 90°, which is set as shown in the table below.

Swing time

Bore size mm [in.]	Total stroke mm	Swing stroke mm	Medium load type ^{Note} s
16 [0.630]	20	10	0.4
	30	10	0.4
25 [0.984]	30	15	0.4
	50	15	0.42
40 [1.575]	30	20	1.3
	50	20	1.4

Note: In the medium load type, the swing time is obtained when piping is directly connected to the cylinder without using a speed control.

The kinetic energy E calculated above should be at or below the allowable kinetic energy listed below.

Exceeding the allowable kinetic energy listed below could damage the rotating mechanism inside the cylinder, resulting in defective operation.

Allowable kinetic energy

J [ft·lbf]

Bore size mm	Medium load type (RHDA)
16 [0.630]	0.003 [0.0021]
25 [0.984]	0.004 [0.0029]
40 [1.575]	0.008 [0.0058]

3. Output torque

Do not apply torque to the Twist cylinder.
The output torque is shown below for reference; it is not a guaranteed value.

Output torque^{Note} (Reference value)

N·m [ft·lbf]

Bore size mm [in.]	Medium load type (RHDA)
16 [0.630]	0.45 [0.33]
25 [0.984]	1.49 [1.10]
40 [1.575]	5.43 [4.01]

Note: Value with air pressure at 0.5MPa [73psi].

Calculation example

When a plate with the dimensions shown below is mounted on the rod end of the Twist cylinder, we select which bore size is the best.

The total stroke is 30mm. The operation time is set at 0.8 second for one push or pull.

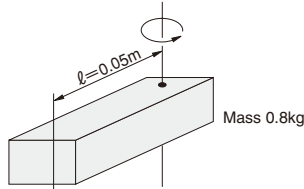

1. For the allowable bending moment

$F = 147\text{N}$ is required.
 $l = 0.05\text{m}$

Therefore, $147 \times 0.05 = 7.35\text{N}\cdot\text{m}$

From the above, we find the medium load type $\phi 25$ cylinder to be suitable here.

2. For the allowable kinetic energy

Based on the medium load type $\phi 25$ that was found to be suitable in **1.** above, we find the allowable kinetic energy.

From $E = \frac{1}{2} J \omega^2$

$$J = \frac{m l^2}{3} = \frac{0.8 \times 0.05^2}{3} = \frac{0.002}{3} \doteq 6.67 \times 10^{-4} (\text{kg}\cdot\text{m}^2)$$

$$\omega = \frac{\theta}{t} = \frac{1.57}{0.4} \doteq 3.93$$

$$E = \frac{1}{2} \times (6.67 \times 10^{-4}) \times (3.93)^2 = 5.15 \times 10^{-3} (\text{J})$$

From the above calculation result, we find the medium load type $\phi 40$ cylinder to be suitable here.

3. For the output torque

Here, we don't need the torque.

As a result of considering **1~3**, we select the medium load type $\phi 40$.

Calculation example

When a plate with the dimensions shown below is mounted on the rod end of the Twist cylinder, we select which bore size is the best.

The total stroke is 1.18in. The operation time is set at 0.8 second for one push or pull.

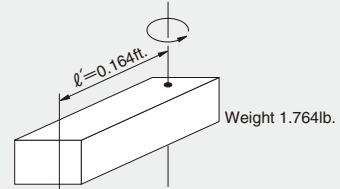

1. For the allowable bending moment

$F' = 33.0\text{lbf.}$ is required.
 $l' = 0.164\text{ft.}$

Therefore, $33.0 \times 0.164 = 5.41\text{ft}\cdot\text{lbf}$

From the above, we find the medium load type $\phi 25$ [0.984in.] cylinder to be suitable here.

2. For the allowable kinetic energy

Based on the medium load type $\phi 25$ [0.984in.] that was found to be suitable in **1.** above, we find the allowable kinetic energy.

From $E' = \frac{1}{2} J' \omega^2$

$$J' = \frac{w l'^2}{3g} = \frac{1.764 \times 0.164^2}{3 \times 32.2} \doteq 4.91 \times 10^{-4} (\text{lb}\cdot\text{ft}\cdot\text{sec}^2)$$

$$\omega = \frac{\theta}{t} = \frac{1.57}{0.4} \doteq 3.93$$

$$E' = \frac{1}{2} \times (4.91 \times 10^{-4}) \times (3.93)^2 = 3.79 \times 10^{-3} (\text{ft}\cdot\text{lbf})$$

From the above calculation result, we find the medium load type $\phi 40$ [1.575in.] cylinder to be suitable here.

3. For the output torque

Here, we don't need the torque.

As a result of considering **1~3**, we select the medium load type $\phi 40$ [1.575in.].

Simplified Selection Chart

Use the simplified selection chart below to quickly select a Twist cylinder.

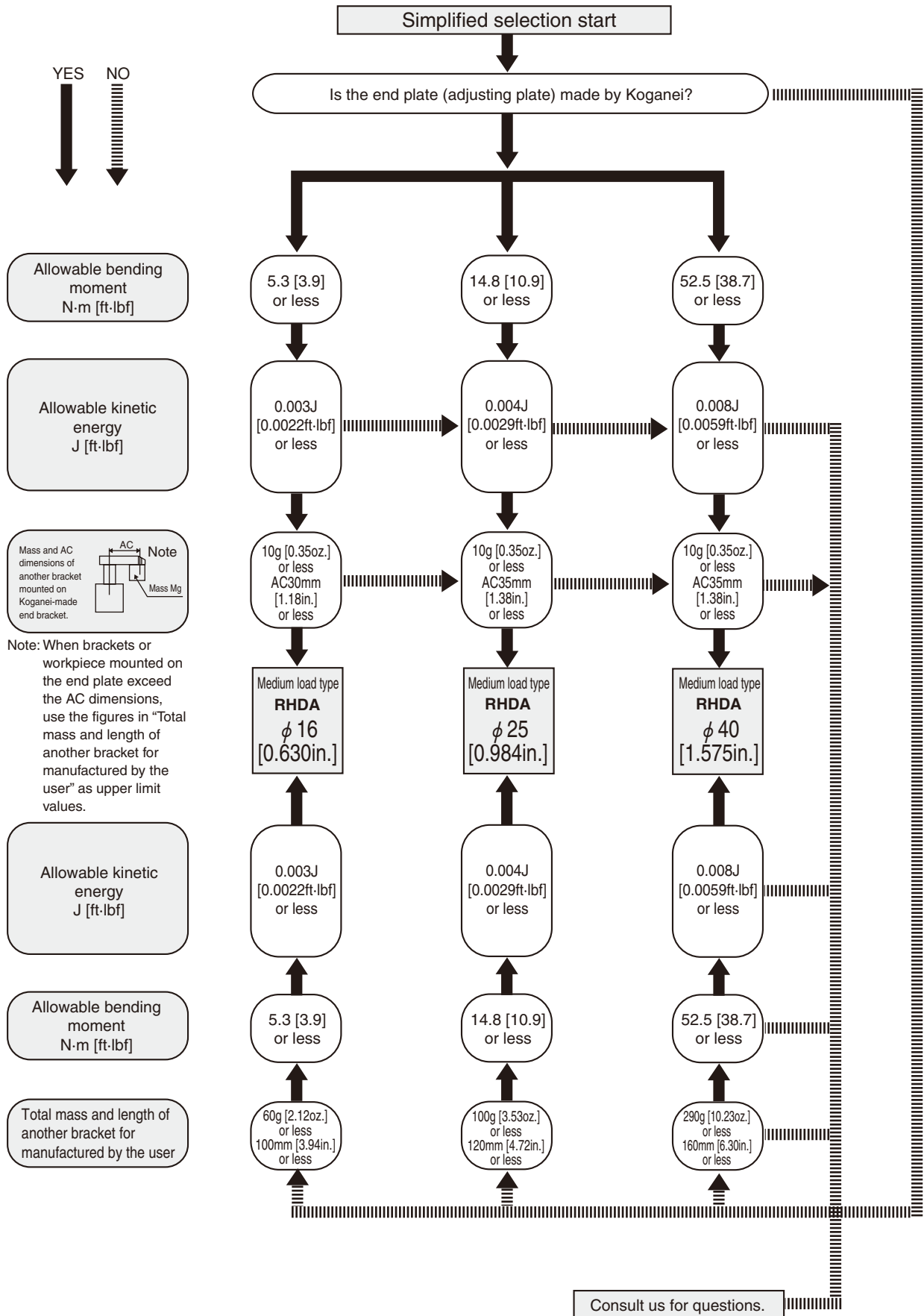

Handling Instructions and Precautions



Mounting

- When mounting an adjusting plate on the rod end, first secure the adjusting plate in place with a wrench or vise, as shown in the illustration below, and tighten a hexagon socket head bolt into the rod end female thread. Care must be exercised that removing or attaching the hexagon socket head bolt without securing the adjusting plate into place with a wrench, etc., could cause the piston rod to rotate, and could damage the rotating mechanism inside the cylinder. Use the same mounting procedure for mounting a fixture other than the adjusting plate to the rod end.

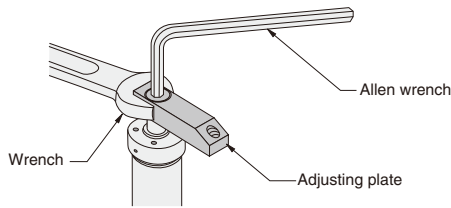

- When rod end brackets are separately manufactured and mounted, the mass and total length of the rod end brackets should not exceed the values shown below.

Bore size mm [in.]	Medium load type (RHDA)	
	Rod end bracket mass g [oz.]	Total length of rod end brackets mm [in.]
16 [0.630]	60 [2.12]	100 [3.94]
25 [0.984]	100 [3.53]	120 [4.72]
40 [1.575]	290 [10.23]	160 [6.30]

Remark: Dimensions of the mounting portion are restricted.
For details, see the AN dimensions and AP dimensions on p.1371.

- When using the Twist cylinder as a clamp for workpieces, do not clamp the workpiece in the course of a swing motion. Clamping the workpiece in the course of a swing motion could damage the rotating mechanism inside the cylinder.
- For installing the body mounting bracket to the cylinder, evenly tighten 2 hexagon socket head bolts at a torque of 392~441N-cm [34.7~39.0in-lbf] (reference values).
When using a ϕ 40 [1.575in.] Twist cylinder with the body mounting bracket, set the pressure at 0.5MPa [73psi.] or less. Using at pressures exceeding 0.5MPa [73psi.] could result in cylinder thrust causing the cylinder body to move from the body mounting bracket. To use in the 0.5~0.7MPa [73~102psi.] range, use a mounting nut or rod cover mounting holes to directly install the cylinder body onto the device.

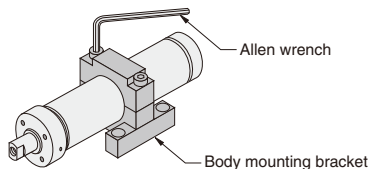

- A piping adapter (order code: -L) can be used to change the piping direction to be perpendicular to the cylinder axis. To install the piping adapter, attach the provided O-ring to the piping adapter's O-ring groove and then assemble it to the cylinder body.



General precautions

Piping

Always thoroughly blow off (use compressed air) the tubing before connecting it to the Twist cylinder. Entering metal chips, sealing tape, rust, etc., generated during piping work could result in air leaks or other defective operation.

Atmosphere

- If using in locations subject to dripping water, dripping oil, etc., or to large amounts of dust, use a cover to protect the unit.
- The product cannot be used when the media or ambient atmosphere contains any of the substances listed below.
Organic solvents, phosphate ester type hydraulic oil, sulphur dioxide, chlorine gas, or acids, etc.

Lubrication

The product can be used without lubrication, if lubrication is required, use Turbine Oil Class 1 (**ISO VG32**) or equivalent. Avoid using spindle oil or machine oil.

Media

- Use air for the media. For the use of any other media, consult us.
- Air used for the Twist cylinder should be clean air that contains no deteriorated compressor oil, etc.
- Install an air filter (filtration of a minimum 40 μ m) near the Twist cylinder or valve to remove collected liquid or dust. In addition, drain the air filter periodically. Collected liquid or dust entering the cylinder may cause improper operation.

TWIST CYLINDERS



Symbol

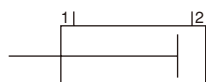

1 : Pull side connection port
2 : Push side connection port

Bore Size and Stroke

Bore size	Stroke ^{Note}
16	20,30
25	30,50
40	30,50

Note: The stroke indicates the total stroke (linear stroke + swing stroke).

Specifications

Item	Type	Medium load type(RHDA)		
		Bore size mm [in.]	16 [0.630]	25 [0.984]
Operation type		Double acting type		
Swing angle		About 90°		
Swing stroke	mm [in.]	10 [0.394]	15 [0.591]	20 [0.787]
Direction of swing ^{Note1}		Left or Right		
Total stroke ^{Note2}	mm [in.]	20, 30 [0.787, 1.181]	30, 50 [1.181, 1.969]	
Allowable moment	N·m [ft·lbf]	5.3 [3.9]	14.8 [10.9]	52.5 [38.7]
Theoretical clamping force ^{Note3}	N [lbf.]	84.3 [19.0]	202 [45.4]	516.8 [116.2]
Media		Air		
Port size		M5×0.8	Rc1/8	
Mounting type		Basic type and body mounting type		
Operating pressure range	MPa [psi.]	0.2~0.7 [29~102]		
Proof pressure	MPa [psi.]	1.03 [149]		
Operating temperature range	°C [°F]	0~60 [32~140]		
Lubrication		Not required		
Cushion		Fixed type (Rubber bumper)		

Notes 1: Direction viewed from the rod end side, in the rod extending movement.

2: Stroke tolerance is ${}^+1_0 [{}^{+0.039}_{0} \text{in.}]$.

(Total stroke) – (Swing stroke) equals the linear stroke.

3: Clamping force after rod retracting (value at air pressure of 0.5MPa [73psi.]).

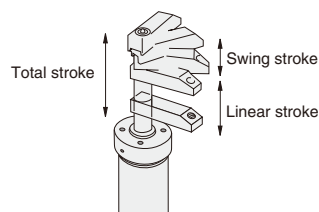

Mass

Bore size × Stroke	Medium load type (RHDA) Body mass	Additional mass					
		Body mounting bracket	Piping adapter	Adjusting plate	Sensor switch ^{Note}		
					With 1 sensor switch	With 2 sensor switches	
16 × 20	0.129 [0.284]	0.048 [0.106]	0.008 [0.018]	0.021 [0.046]	0.03 [0.07]	0.06 [0.13]	
16 × 30	0.150 [0.331]						
25 × 30	0.355 [0.783]	0.075 [0.165]	0.030 [0.066]	0.040 [0.088]	0.03 [0.07]	0.06 [0.13]	
25 × 50	0.443 [0.977]						
40 × 30	0.950 [2.095]	0.143 [0.315]	0.095 [0.209]	0.090 [0.198]	0.03 [0.07]	0.06 [0.13]	
40 × 50	1.128 [2.487]						

Note: The additional mass of the sensor switch is the mass of the sensor body mounting strap added to the sensor body only, and does not include the lead wire mass.

Air Consumption

The figures in the table below show the air consumption when a Twist cylinder makes 1 reciprocation with stroke of 1mm [0.0394in.].
The air consumption and flow rate actually required is found by the following calculations.

Air consumption for each 1mm [0.0394in.] stroke

Bore size mm [in.]	Air pressure MPa [psi.]						
	0.1 [15]	0.2 [29]	0.3 [44]	0.4 [58]	0.5 [73]	0.6 [87]	0.7 [102]
16 [0.630]	0.79 [0.0482]	1.18 [0.0720]	1.57 [0.0958]	1.96 [0.1196]	2.35 [0.1434]	2.74 [0.1672]	3.13 [0.1910]
25 [0.984]	1.94 [0.1184]	2.89 [0.1764]	3.83 [0.2337]	4.79 [0.2923]	5.75 [0.3509]	6.71 [0.4095]	7.67 [0.4681]
40 [1.575]	4.95 [0.3021]	7.40 [0.4516]	9.83 [0.5999]	12.26 [0.7482]	14.69 [0.8964]	17.16 [1.0472]	19.60 [1.1961]

● Finding the air consumption

Example 1. When operating a Twist cylinder with bore size of 16mm [0.630in.] and stroke of 20mm [0.787in.] and under air pressure of 0.5MPa [73psi.] for 1 reciprocation

$$\frac{2.35}{\text{From the table}} \times \frac{20}{\text{Stroke}} \times 10^{-3} = 0.047 \text{ l/Reciprocation} \quad [0.0017\text{ft}^3/\text{Reciprocation}] \text{ (ANR)}^{**}$$

Example 2. When operating a Twist cylinder with bore size of 16mm [0.630in.] and stroke of 20mm [0.787in.] and under air pressure of 0.5MPa [73psi.] for 20 reciprocations per minute

$$\frac{2.35}{\text{From the table}} \times \frac{20}{\text{Stroke}} \times \frac{20}{\text{Number of operations per minute (reciprocations)}} \times 10^{-3} = 0.94 \text{ l/min} \quad [0.033\text{ft}^3/\text{min.}] \text{ (ANR)}^{**}$$

● Finding the air flow (For selecting F.R.L., valves, etc.)

Example: When operating a Twist cylinder with bore size of 16mm [0.630in.] at speed of 100mm/s [3.94in./sec.] and under air pressure of 0.5MPa [73psi.]

$$\frac{2.35}{\text{From the table}} \times \frac{100}{\text{Speed: mm/s}} \times \frac{1}{2} \times 10^{-3} = 0.1175 \text{ l/s} \quad [0.00415\text{ft}^3/\text{sec.}] \text{ (ANR)}^{**}$$

(At this time, the flow rate per minute is $0.1175 \times 60 = 7.05 \text{ l/min}$)

[0.249ft³/min.] (ANR)**

**Refer to p.54 for an explanation of ANR.

Cylinder Thrust

Bore size mm [in.]	Rod diameter mm [in.]	Operation	Pressure area mm ² [in. ²]	Air pressure MPa [psi.]							
				0.1 [15]	0.2 [29]	0.3 [44]	0.4 [58]	0.5 [73]	0.6 [87]	0.7 [102]	
16 [0.630]	6 [0.236]	Double acting type	Push side	201 [0.312]	20.1 [4.52]	40.2 [9.04]	60.3 [13.56]	80.4 [18.07]	100.5 [22.59]	120.6 [27.11]	140.7 [31.63]
			Pull side	172 [0.267]	17.2 [3.87]	34.4 [7.73]	51.6 [11.60]	68.8 [15.47]	86.0 [19.33]	103.2 [23.20]	120.4 [27.07]
25 [0.984]	10 [0.394]	Double acting type	Push side	490 [0.760]	49.0 [11.02]	98.0 [22.03]	147.0 [33.05]	196.0 [44.06]	245.0 [55.08]	294.0 [66.09]	343.0 [77.11]
			Pull side	412 [0.639]	41.2 [9.26]	82.4 [18.52]	123.6 [27.79]	164.8 [37.05]	206.0 [46.31]	247.2 [55.57]	288.4 [64.83]
40 [1.575]	16 [0.630]	Double acting type	Push side	1256 [1.947]	125.6 [28.23]	251.2 [56.47]	376.8 [84.70]	502.4 [112.94]	628.0 [141.17]	753.6 [169.41]	879.2 [197.64]
			Pull side	755 [1.170]	75.5 [16.97]	151.0 [33.94]	226.5 [50.92]	302.0 [67.89]	377.5 [84.86]	453.0 [101.83]	528.5 [118.81]

N [lbf.]

Inner Construction and Major Parts

● Medium load type (RHDA: Pin guide type)

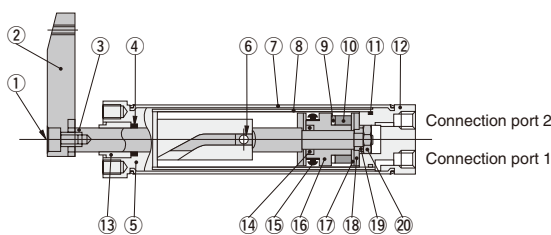















Remark: The positional relationship between the connection ports and the adjusting plate (2) when the piston is retracted is shown in the diagram to the left.

Major Parts and Materials

No.	Parts	Bore size mm [in.]			No.	Parts	Bore size mm [in.]		
		16 [0.630]	25 [0.984]	40 [1.575]			16 [0.630]	25 [0.984]	40 [1.575]
①	Hexagon socket head bolt	Chrome molybdenum steel			⑪	O-ring	Synthetic rubber (NBR)		
②	Adjusting plate	Steel (nickel plated)			⑫	Head cover	Aluminum alloy (anodized)		
③	Piston rod	Stainless steel (hard chrome plated)	Steel (hard chrome plated)		⑬	Rod bushing	Oil impregnated bushing		
④	Rod seal	Synthetic rubber (NBR)			⑭	O-ring	Synthetic rubber (NBR)		
⑤	Rod cover	RHDA: Steel (resin impregnated coating)			⑮	Piston seal	Synthetic rubber (NBR)		
⑥	Pin	Stainless steel			⑯	Piston	Plastic		
⑦	Outer cylinder tube	Stainless steel			⑰	Retaining washer	Steel		
⑧	Inner cylinder tube	Brass			⑱	Bumper	Synthetic rubber (NBR)		
⑨	Spacer	Brass	—		⑲	Washer	Steel		
⑩	Magnet	Rubber magnet	Plastic magnet		⑳	Hexagon nut	Steel		

Order Codes

Basic type	Direction of swing	Mounting type	Piping adapter	Adjusting plate	Sensor switch (Model, lead wire length, quantity)						
<p>Medium load type</p>  <p>RHDA</p> <p>● Pin guide type</p>	<p>Right direction swing</p>  <p>-ER</p> <p>● Rotates clockwise when rod extended, as viewed from the rod end.</p> <p>Left direction swing</p>  <p>-EL</p> <p>● Rotates counter-clockwise when rod extended, as viewed from the rod end.</p>	<p>Basic type</p>  <p>Blank</p> <p>Body mounting type</p>  <p>-1C</p> <p>● The body mounting bracket is included. For the shape of the body mounting bracket, see p.1371.</p> <p>● Order codes for body mounting bracket only 1C-RDA □ (□ : Bore size 16,25,40)</p>	<p>No piping adapter</p>  <p>Blank</p> <p>With piping adapter</p>  <p>-L</p> <p>● Can change the piping direction to be perpendicular to the cylinder axis. For the shape of the piping adapter, see p.1371.</p>	<p>No adjusting plate</p>  <p>Blank</p> <p>With adjusting plate</p>  <p>-AP</p> <p>● Adjusting plate is included at shipping.</p> <p>● Order codes for adjusting plate only AP-RDA □ (□ : Bore size 16,25,40)</p>	<p>No sensor switch</p>  <p>Blank</p> <p>With ZG530</p>  <p>-ZG530</p> <p>● Solid state type</p> <p>● With indicator lamp</p> <p>● DC10~28V</p> <p>With ZG553</p>  <p>-ZG553</p> <p>● Solid state type</p> <p>● With indicator lamp</p> <p>● DC4.5~28V</p>	<p>With CS3M</p>  <p>-CS3M</p> <p>● Reed switch type</p> <p>● With indicator lamp</p> <p>● DC10~30V</p> <p>● AC85~230V</p> <p>With CS4M</p>  <p>-CS4M</p> <p>● Reed switch type</p> <p>● With indicator lamp</p> <p>● DC10~30V</p> <p>● AC85~115V</p> <p>With CS5M</p>  <p>-CS5M</p> <p>● Reed switch type</p> <p>● Without indicator lamp</p> <p>● DC3~30V</p> <p>● AC85~115V</p>	<p>● Lead wire length</p> <p>A : 1000mm [39in.]</p> <p>B : 3000mm [118in.]</p> <p>● Number of sensor switches</p> <p>1: With 1 sensor switch</p> <p>2: With 2 sensor switches</p> <p>⋮</p>				
	<p>Bore size × Stroke</p>	<p>Swing angle (90° only)</p>	<p>Connection port location (head side piping only)</p>								
RHDA	×	-90	-ER -EL	-HA	-1C	-L	-AP	-ZG530 -ZG553 -CS3M -CS4M -CS5M	A B	1 2 ⋮	

● For the order codes of sensor switches only, see p.1372.

Dimensions (mm)

● Basic type

● Medium load type (RHDA)

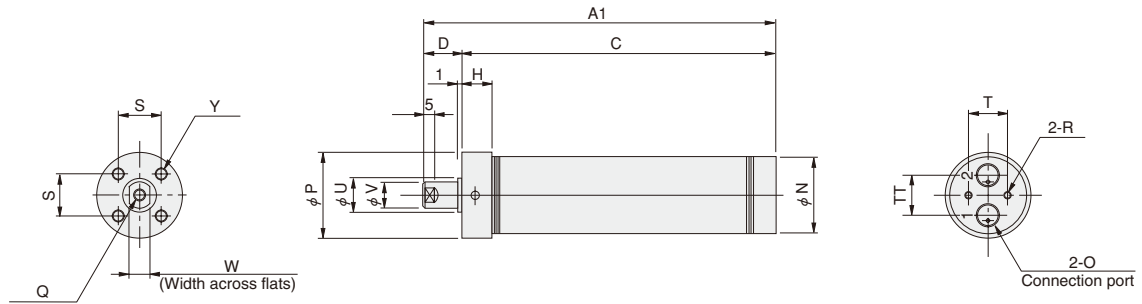

● With adjusting plate

● Medium load type (RHDA)

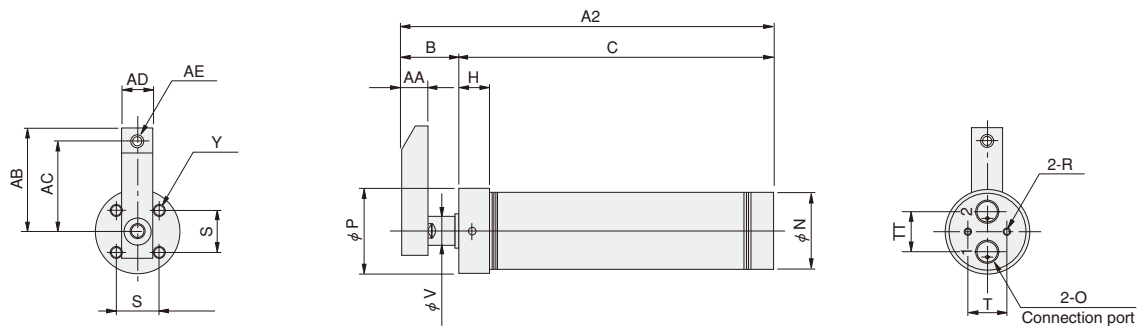

Bore size mm [in.]	A1			A2			B	C			D	H	I	J	M
	20st.	30st.	50st.	20st.	30st.	50st.		20st.	30st.	50st.					
16 [0.630]	108.5	128.5	—	113.5	133.5	—	16.5	97	117	—	11.5	8	22	8.0	25.4
25 [0.984]	—	143.5	183.5	—	150.5	190.5	20.5	—	130	170	13.5	10	30	9.5	34.6
40 [1.575]	—	163.0	203.0	—	174.5	214.5	27.5	—	147	187	16.0	12	41	9.5	47.3

Bore size mm [in.]	N	O	P	Q	R	S	T	TT	U	V	W	Y	AA	AB	AC	AD	AE
16 [0.630]	19.0	M5×0.8 Depth4	22	M3×0.5 Depth5	M3×0.5 Depth6	12	11	11	8 ⁰ _{-0.05}	6 ^{-0.013} _{-0.035}	5 ⁰ _{-0.2}	4-M3 Depth5.5	8	35	30	10	M3×0.5
25 [0.984]	28.8	Rc1/8 Depth7	32	M5×0.8 Depth8	M4×0.7 Depth6	16	15	15	12 ⁰ _{-0.05}	10 ^{-0.013} _{-0.035}	8 ⁰ _{-0.2}	4-M5 Depth7.5	10	40	35	12	M5×0.8
40 [1.575]	44.6	Rc1/8 Depth7	50	M8×1.25 Depth10	M5×0.8 Depth7	26	26	26	20 ⁰ _{-0.05}	16 ^{-0.016} _{-0.043}	12 ⁰ _{-0.2}	4-M6 Depth9.5	16	45	35	16	M6×1

Dimensions (mm)

● Adjusting plate

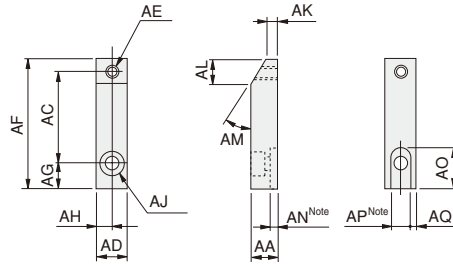

Note: For manufacturing another adjusting plate, always provide these width across flats dimensions.

● Body mounting type

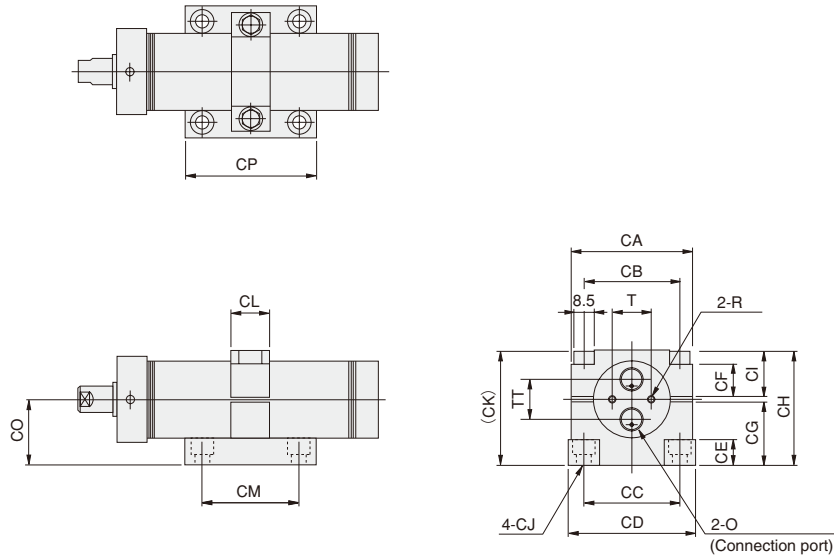

● With piping adapter

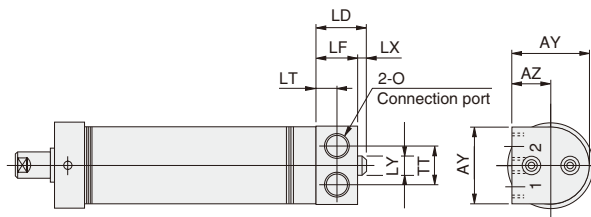

Bore size mm [in.]	AA	AD	AE	AF	AG	AH	AJ	AK	AL	AM	AN	AO	AP	AQ
16 [0.630]	8	10	M3×0.5	40	5	5	φ 3.5 Counterbore φ 6.5 Depth3.3	5	10	15°	3.0	9.5	5 ^{+0.1} _{+0.05}	2.5
25 [0.984]	10	12	M5×0.8	50	10	6	φ 5.5 Counterbore φ 9.5 Depth5.4	5	9	30°	3.0	16.0	8 ^{+0.1} _{+0.05}	2.0
40 [1.575]	16	16	M6×1	55	10	8	φ 9 Counterbore φ 14 Depth8.6	8	14	30°	4.5	22.0	12 ^{+0.1} _{+0.06}	2.0

Bore size mm [in.]	C	O	R	T	TT	CA	CB	CC	CD	CE	CF	CG
16 [0.630]	53	M5×0.8 Depth4	M3×0.5 Depth6	11	11	37	28±0.3	26±0.2	40	10	10.5	19.5
25 [0.984]	70	Rc1/8 Depth7	M4×0.7 Depth6	15	15	47	38±0.3	38±0.2	50	10	13.5	24.5
40 [1.575]	83	Rc1/8 Depth7	M5×0.8 Depth7	26	26	63	54±0.3	46±0.2	65	11	21.5	29.5

Bore size mm [in.]	CH	CI	CJ	CK	CL	CM	CO	CP	LD	LF	LT	LX	LY	AY	AZ
16 [0.630]	33.5	13.5	φ 5.5 Counterbore φ 9.5 Depth5.4	36	10	26±0.3	20	40	9	8	4	1	5.5	20.0	10.0
25 [0.984]	44.5	19.5	φ 5.5 Counterbore φ 9.5 Depth5.4	44	15	38±0.3	25	50	19	16	8	3	7.0	29.8	14.9
40 [1.575]	60.0	30.0	φ 6.5 Counterbore φ 11 Depth6.5	57	20	46±0.3	30	60	19	16	8	3	8.5	51.0	25.5

SENSOR SWITCHES

Solid State Type, Reed Switch Type

Order Codes for Sensor Switches

● Sensor switches (with mounting strap)

Sensor switch model	Lead wire length	For Twist cylinder	Bore size
ZG530	A B	-RDA	16 25 40
ZG553			
CS3M			
CS4M			
CS5M			

● A : 1000mm [39in.] B : 3000mm [118in.]

● For details of sensor switches, see p.1544.

● Order codes for mounting straps only

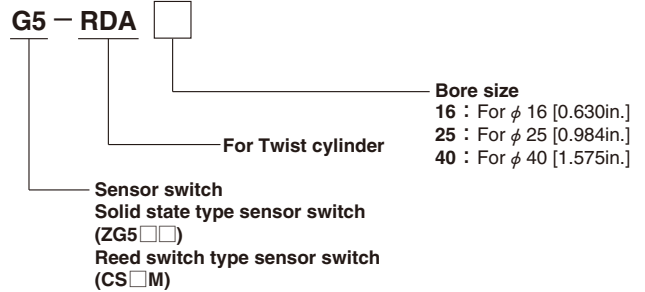

Mounting Location of Sensor Switch

When the sensor switch is mounted in the locations shown below and the piston comes to the end of the stroke, the magnet mounted on the piston comes to the maximum sensing location of the sensor switch.

● Medium load type (RHDA)

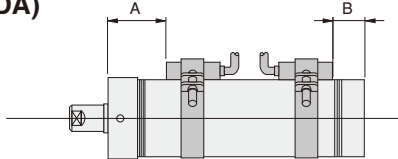

Bore size	Stroke	Medium load type (RHDA)	
		A	B
16 [0.630]	20st	47.0 [1.850]	9.0 [0.354]
	30st	57.0 [2.244]	
25 [0.984]	30st	64.5 [2.539]	13.5 [0.531]
	50st	84.5 [3.327]	
40 [1.575]	30st	75.0 [2.953]	20.0 [0.787]
	50st	95.0 [3.740]	

Sensor Switch Operating Range, Response Differential, and Maximum Sensing Location

● Operating range: ℓ

The distance the piston travels in one direction, while the switch is in the ON position.

● Response differential: C

The distance between the point where the piston turns the switch ON and the point where the switch is turned OFF as the piston travels in the opposite direction.

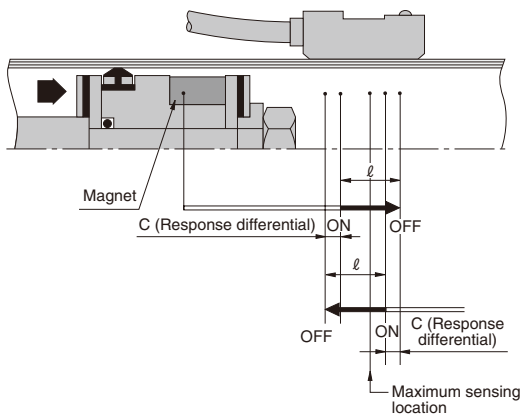

Bore size	ZG530□, ZG553□			CS□M□		
	Operating range	Response differential	Maximum sensing location ^{Note}	Operating range	Response differential	Maximum sensing location ^{Note}
16 [0.630]	2.0~3.3 [0.079~0.130]	0.7 [0.028] or less	11 [0.433]	6.0~7.0 [0.236~0.276]	1.5 [0.059] or less	11 [0.433]
25 [0.984]	2.5~4.2 [0.098~0.165]			7.0~8.5 [0.276~0.335]		
40 [1.575]	3.1~5.0 [0.122~0.197]	0.8 [0.031] or less		9.5~11.0 [0.374~0.433]		

Remark: The above table shows reference values.

Note: This is the length measured from the switch's opposite end side to the lead wire.

Moving Sensor Switch

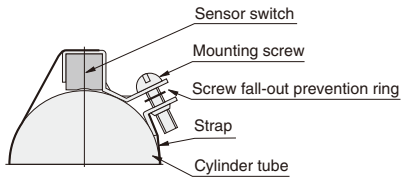

- Loosening the mounting screw allows the sensor switch to be moved with the strap either along the axial or circumference direction of the cylinder.
The sensor switch alone cannot be moved.
- To remove the sensor switch from the strap, first remove the strap from the cylinder tube and then remove the sensor switch from the strap.
- Tighten the mounting screw with a tightening torque of 49N·cm [4.3in·lbf].

Dimensions of Sensor Switch

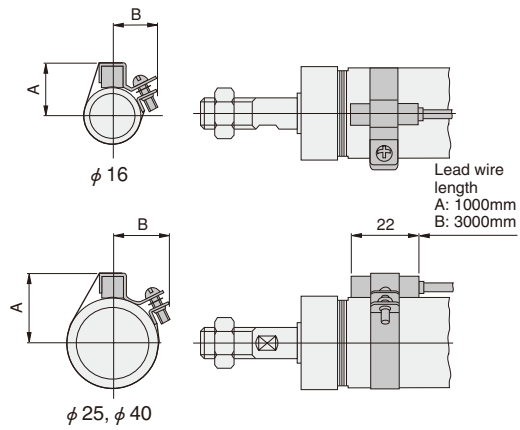

		mm [in.]	
Bore	Code	A	B
16	0.630	17.0 [0.669]	15 [0.591]
25	0.984	22.5 [0.886]	18 [0.709]
40	1.575	30.0 [1.181]	—

※ When using $\phi 40$ [1.575in.], the B dimension is the external radius of the cylinder tube. In this case, the mounting protrusion in the B direction disappears.