

# Seven Features of the Koganei Vacuum Valve

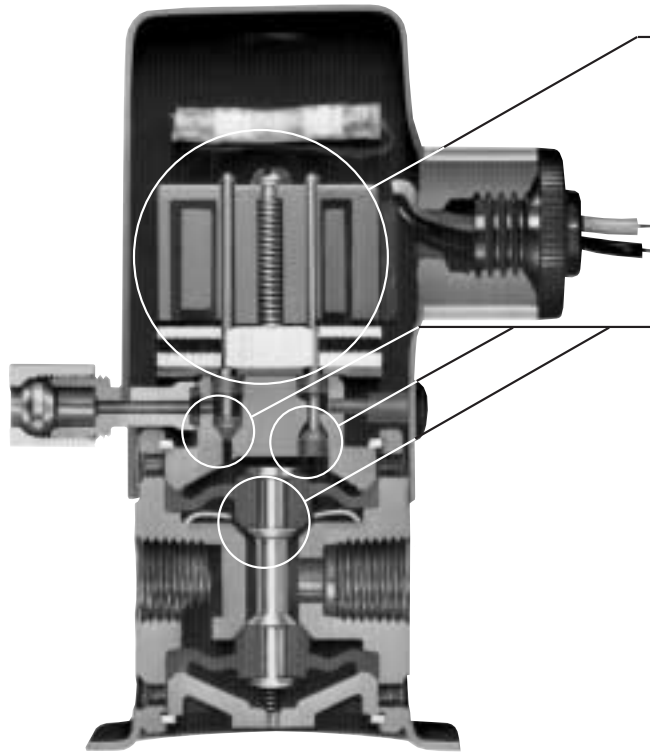

## Koganei Original Solenoid Construction

- ① **No burning damage to solenoid**  
No need to stock solenoids as spare parts.
- ② **Starting and energizing current values are extremely small.**  
Allows for more compact size peripheral electrical equipment.

## Poppet and Diaphragm Construction

- ③ **No sliding parts**  
No valve sticking, for reliable operations.
- ④ **Extremely few cases of vacuum leakage**  
Good vacuum response enables excellent pick-up by a vacuum pad and compact vacuum pump to install.
- ⑤ **Dust-resistant**  
Can be used by installing just an ordinary air filter, even in dusty locations.
- ⑥ **Can be used without lubrication.**  
Optimum valve for equipment incapable of using oil.
- ⑦ **Compact and lightweight, with any mounting direction acceptable**  
Can be easily mounted to control panel, and allows for more compact equipment.

## Application Examples

### Opening bags

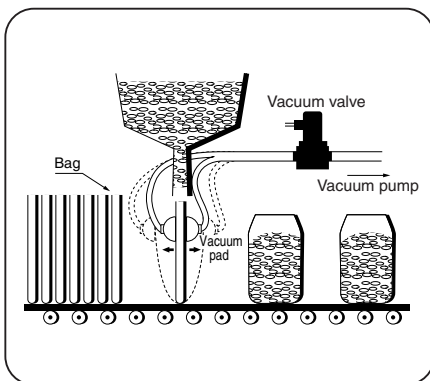

### Quick charging of liquids

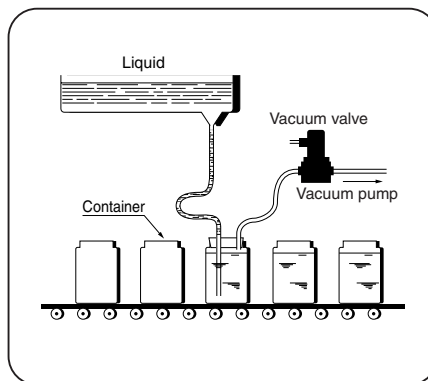

### Paper feeding for printers

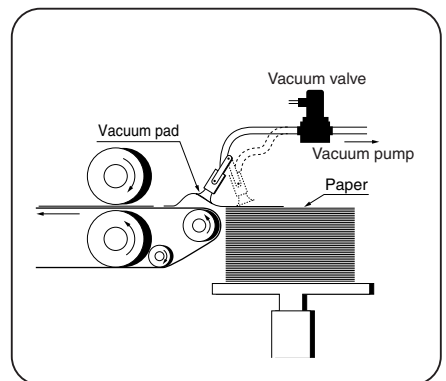

### Vacuum forming machines

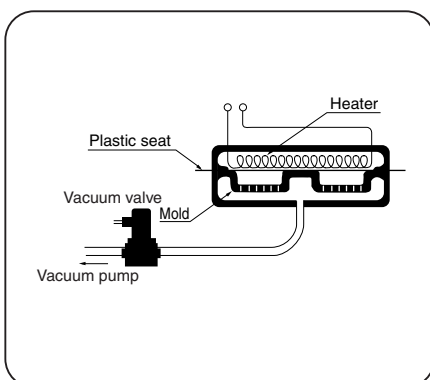

### Discriminating product facing

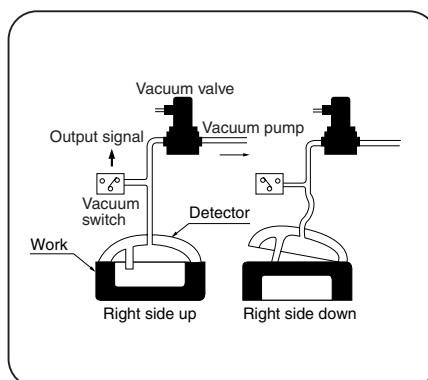

### Labeling on cardboard boxes

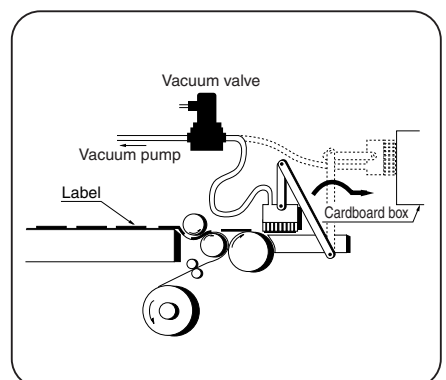

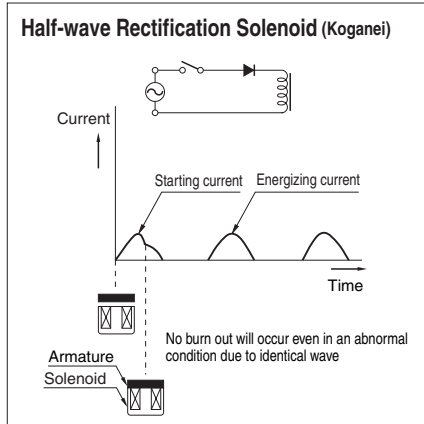
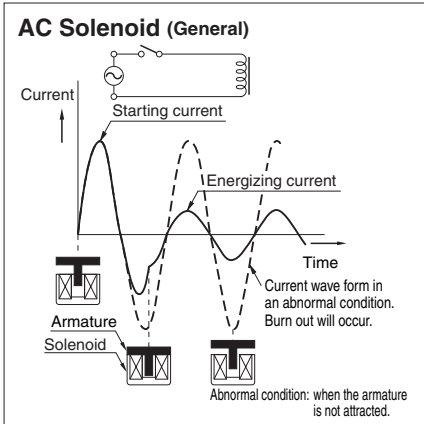

### Koganei's ingenious self-developed solenoid

A silicon diode is installed on the end of the solenoid for half-wave rectification of the alternating current. The solenoid, therefore, possesses midway characteristics between the AC solenoid and DC solenoid. In addition, since the armature is designed to move as short a distance as possible, the starting current (inrush current) and energizing current are virtually identical and low current. As a result, the solenoid is not damaged even in abnormal conditions in which the armature fails to move, and the capacity of related electrical equipment can remain low.

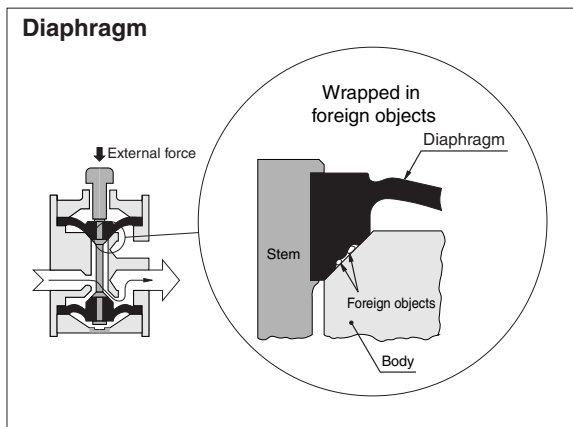
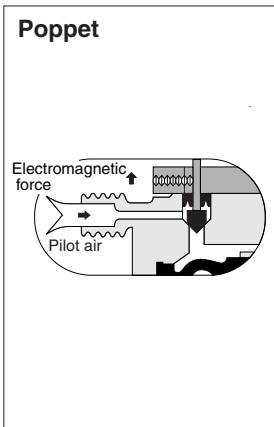

### Poppet and diaphragm construction

The synthetic rubber poppet and diaphragm are built into the stem and move as one-piece. The poppet and diaphragm do not have any sliding surfaces, therefore no sticking occurs even without lubrication. In addition, the units have the elasticity of synthetic rubber to wrap in small foreign objects and keep vacuum leaks to an extremely low level.

### Vacuum lifting

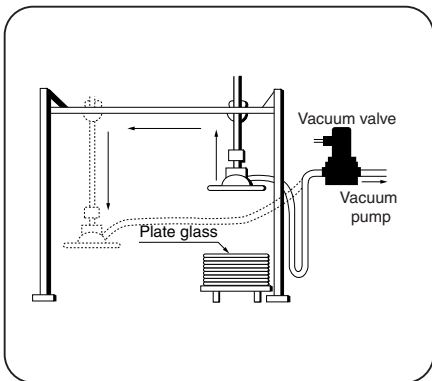

### Reducing sheet transfer time (both vacuum and positive pressure)

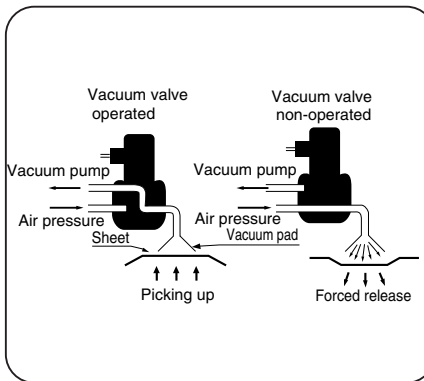

### Tape speed controlling

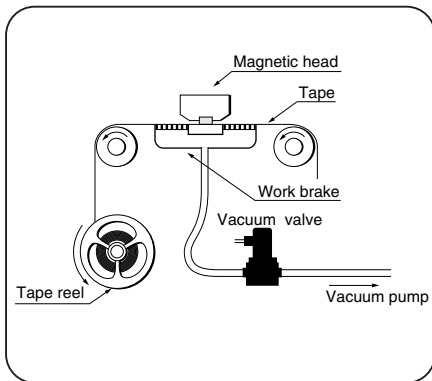

### Holding subject (sheets)

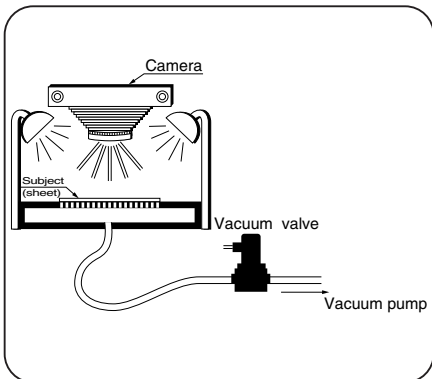

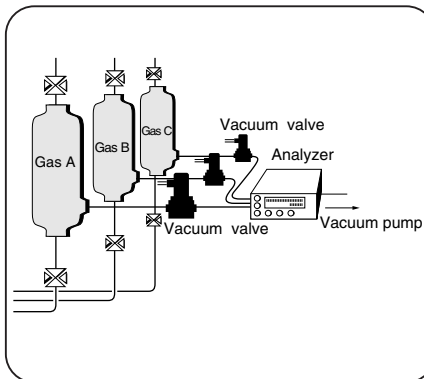

### Inducing gas into analyzers

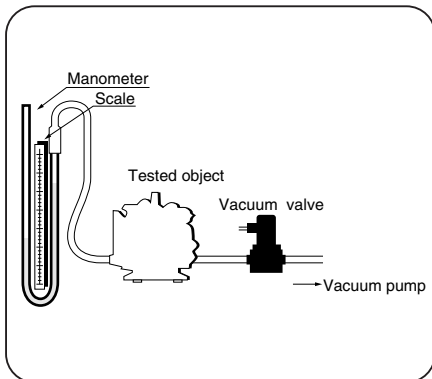

### Airtightness inspecting

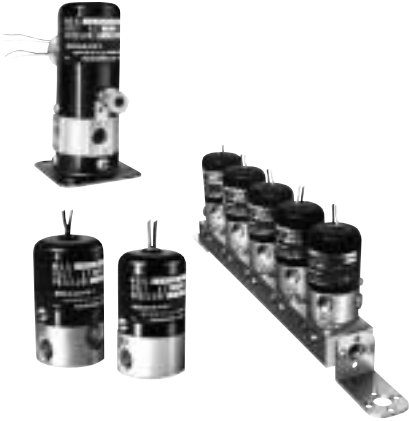
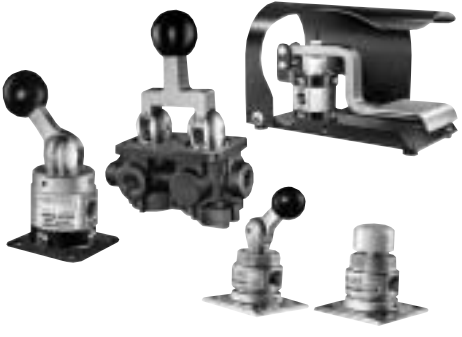

# <Product Range>

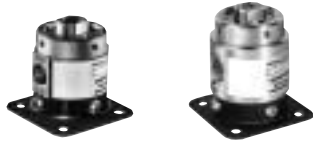
Products	Shape	Operation type		Port size Rc	Port	Function	Effective area (Cv) mm <sup>2</sup>	Model	Page			
Solenoid vacuum valve		Single solenoid	Direct acting	1/4	2, 3	●NC ●NO	2.5 (0.12)	V062E1	961			
							5.5 (0.27)	SV062E1 (Both vacuum and pressure type)				
							15 (0.76)	V126E1				
			Indirect acting { External air pilot }	3/8	3		55 (2.7)	VA250AE1				
							55 (2.7)	VA2503AE1				
							55 (2.7)	VA500AE1				
		Indirect acting { External vacuum pilot }	1/4	3	15 (0.76)	VV250AE1						
					15 (0.76)	VV2503AE1						
					55 (2.7)	VV500AE1						
		Double solenoid (Continuously energizing type)	Indirect acting { External air pilot }	1/4	3	●NC/ NO	15 (0.76)	VA250AE2	964			
55 (2.7)	VA2503AE2											
55 (2.7)	VA500AE2											
Manual vacuum valve and foot vacuum valve		Push button	Spring return	1/8	3	●NC	5.5 (0.27)	V125P	970			
							With holding mechanism	1/4		15 (0.76)	V250P	
								3/8		V2503P		
		Lever	Holding type	1/8	3	●NC/ NO	5.5 (0.27)	V125HO				
							1/4	V125V				
							3/8	V250V				
							1/4	V2503V				
							3/8	V250-4H				
		Foot	Pedal type	1/4	5	—	15 (0.76)	V2503-4H				
							2, 3	●NC		V250F		
Mechanical operated vacuum valve		Ball-cam		1/8	3	●NC	5.5 (0.27)	V125B	973			
							1/4	3		●NC	V250B	
											3/8	V2503B
		Roller-cam		1/4	2, 3	●NC	15 (0.76)	V250C				
							3/8	V2503C				
				Steel roller	1/8		3	5.5 (0.27)		V125MC		
One way steel roller	V125MOC											
Piloted vacuum valve		Air pilot (single)		1/8	3	●NC	5.5 (0.27)	VA125A	976			
							1/4	3		●NC	15 (0.76)	VA250A
											3/8	VA2503A
		Vacuum pilot (single)	1/2	3	●NC	55 (2.7)	VA500A					
						1/4	15 (0.76)	VV250A				
						3/8	VV2503A					
		Double air pilot		1/4	2, 3	●NC/ NO	15 (0.76)	250A2		979		
							3/8	2503A2				
							1/2	500A2				
							3/4	750A2				
			1			280 (14)	1000A2					

## Safety Precautions (Solenoid Vacuum Valve Series)



### Warnings

1. When mounting a valve inside a control panel or when an operation requires long energizing periods, provide heat radiation measures to ensure that the ambient temperature always remains within the temperature range specifications. For long term continuous energizing, consult us.
2. Always check the Catalog, etc., when carrying out wiring and piping of products to ensure that the connections are correctly done. Wrong wiring or piping could result in abnormal operation to the actuator, etc.
3. The solenoid valve's silicon diode could be damaged by surge voltage when a large induction load is used on the same power supply. Either change to a separate power supply, or mount a surge absorber to protect the unit. Solenoids with surge suppression are also available. Consult us.



### Caution

For locations subject to water or to large amounts of dust, use a cover, etc., to protect the valves. Also, install a muffler, etc., to the R port to prevent dust from entering. Intrusion of water or dust could result in short-term functional shutdowns, sudden drops in performance, or a reduced operating life.



### Attention

1. Use clean air that does not contain degraded compressor oil, etc., and install a filter, etc., close to solenoid valves to remove dust or collected liquid.
2. Ensure that the piping port on the supply side is at the same area or larger than the solenoid valve's effective area.
3. When using an indirect acting valve, use a stop valve between it and the pressure source. When the stop valve is opened before the pressure reaches the minimum operating pressure, the indirect acting valve could fall into a neutral position. (All solenoid valves in the 250 series and up are indirect acting valves.)
4. When connecting 2 or more AC type solenoid valves to the same power supply, connect leads with the same lead wire color.
5. Since a diode is connected to the AC type solenoid valve, the solenoid may sometimes not turn on with the solid state-type relay (SSR) with zero-cross function. For this reason, pay attention before use to the ratings and precautions for use of the solid state-type relay.

## Voltage Types and Current

Rated voltage V	Current A <sup>Note</sup>		
	50Hz	60Hz	
AC	230 <sup>※</sup>	0.063	0.055
	220 <sup>※</sup>	0.058	0.072
	200	0.070	0.065
	115 <sup>※</sup>	0.13	0.11
	110 <sup>※</sup>	0.12	0.16
	100	0.14	0.13
	48 <sup>※</sup>	0.41	0.37
	24 <sup>※</sup>	0.93	0.83

Note: The starting current and energizing current values are virtually identical, and fall within these values.

Rated voltage V	Current A	
DC	200 <sup>※</sup>	0.04
	110 <sup>※</sup>	0.08
	100 <sup>※</sup>	0.09
	48 <sup>※</sup>	0.19
	24	0.40
	12 <sup>※</sup>	0.75
	6 <sup>※</sup>	1.50

For ※ items, consult us for the delivery.

## Wiring Instructions of Double Solenoid (E2) Type

This valve has 2 solenoids built into the top and mid section, and the lead wires are color-coded with vinyl tape. Energizing the red tape side (the upper side, solenoid S2) opens the valve, and energizing the gray tape side (the lower side, solenoid S1) closes the valve. This solenoid is a continuous energizing holding type.

### Solenoid S1 energized

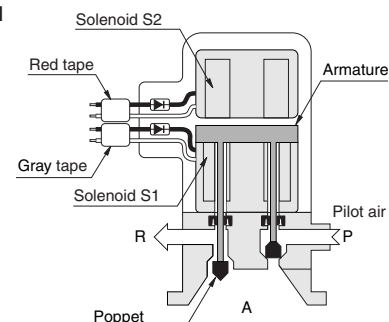

# Solenoid Vacuum Valves 500 Series

3-port, External Pilot Type

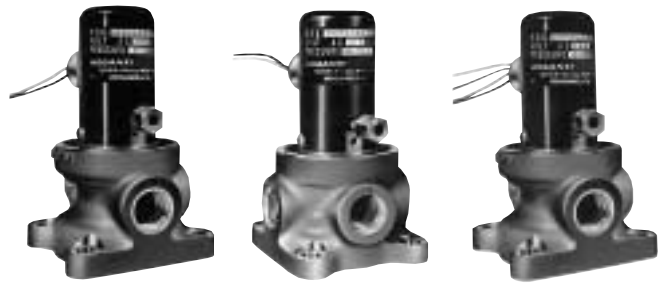

## Specifications

Item	Basic model	VA500AE1	VV500AE1	VA500AE2
Media		Vacuum, air		
Operation type		Indirect acting		
Number of ports		3 ports		
Valve function		Single solenoid Normally closed (NC, standard), Normally open (NO, optional)		Double solenoid Normally closed (NC), Normally open (NO)
Effective area [Cv] mm <sup>2</sup>		55 [2.7]		
Port size Rc		1/2		
Lubrication		Not required		
Operating pressure range kPa[mmHg] [in.Hg]		0~-100 {0~-750} [0~-29.53]	-51~-100 {-380~-750} [-14.96~-29.53]	0~-100 {0~-750} [0~-29.53]
External pilot pressure		Recommended pilot air pressure 0.2~0.3MPa [29~44psi.] MAX.0.5MPa [73psi.]	Pilot vacuum -51~-100kPa [-14.96~-29.53in.Hg]	Recommended pilot air pressure 0.2~0.3MPa [29~44psi.] MAX.0.7MPa [102psi.]
External pilot port size		φ 6 [0.236in.] flareless fitting (For nylon tube)		
Operating temperature range °C [°F]		5~60 [41~140]		
Voltage type V		Standard AC100 (50/60Hz), AC200 (50/60Hz), For other voltages, see p.960.		
Voltage fluctuations %		±10		
Current <sup>Note</sup> A	AC100V	50Hz → 0.14, 60Hz → 0.13		
	AC200V	50Hz → 0.070, 60Hz → 0.065		
Energizing type		Continuous energizing		
Insulation type		B type		
Wiring connection type		Conduit		
Lead wire length mm [in.]		Approximately 300 [11.8]		
Mounting direction		Any		
Mass kg [lb.]		0.85 [1.87]		0.95 [2.09]

Note: The starting current and energizing current values are virtually identical, and fall within these values.

## Solenoid Vacuum Valve Order Codes

		Basic model	Option	With barbed fitting for pilot	Voltage
Single solenoid	Air pilot	VA500AE1	-11	-62	AC100V AC200V
	Vacuum pilot	VV500AE1			
Double solenoid	Air pilot	VA500AE2			

## Handling Instructions and Precautions

- When using in dusty atmospheres, install a filter between the vacuum pad and the solenoid valve, and at the R port.
- For the wiring instructions of VA500AE2, see p.960.
- Maintain pilot vacuum at -51kPa {-380mmHg} [-14.96in.Hg] or more for the VV500AE1.

- Single solenoid only
- Blank: Normally closed (NC)
- E2: Both normally closed (NC) and normally open (NO)

● For inner diameter φ 6 [0.236in.] rubber tube

# Operating Principles and Symbols

## External air pilot type (VA500AE1)

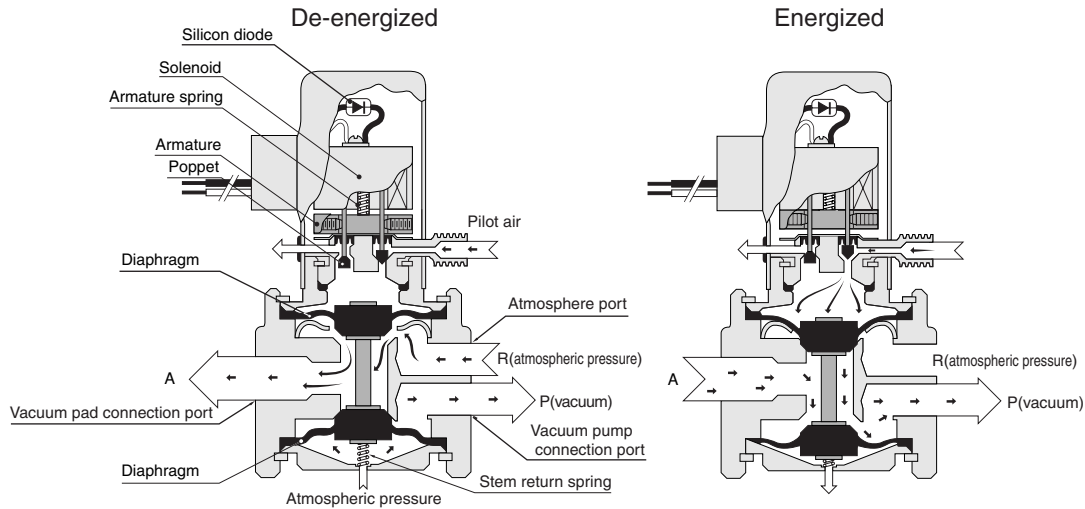

### Explanation of operation

- When de-energized, the armature is separated from the solenoid by the armature spring. The right-side poppet directly connected to the armature closes, while the left-side poppet opens, making the pressure on the upper surface of the upper diaphragm atmospheric pressure. Therefore, the lower diaphragm is pulled up by the stem return spring and the vacuum (main) applied to the upper surface of the lower diaphragm, closing the P port, and connecting the A port and R port.
- When energized, the armature is attracted to the solenoid, opening the right-side poppet and closing the left-side poppet, bringing pilot air to the upper surface of the upper diaphragm. The diaphragm is therefore pushed downward, closing the R port, and connecting the P port and A port.

NC	NO	NC/NO
VA500AE	VA500AE-11	VA500AE2

## External vacuum pilot type (VV500AE1)

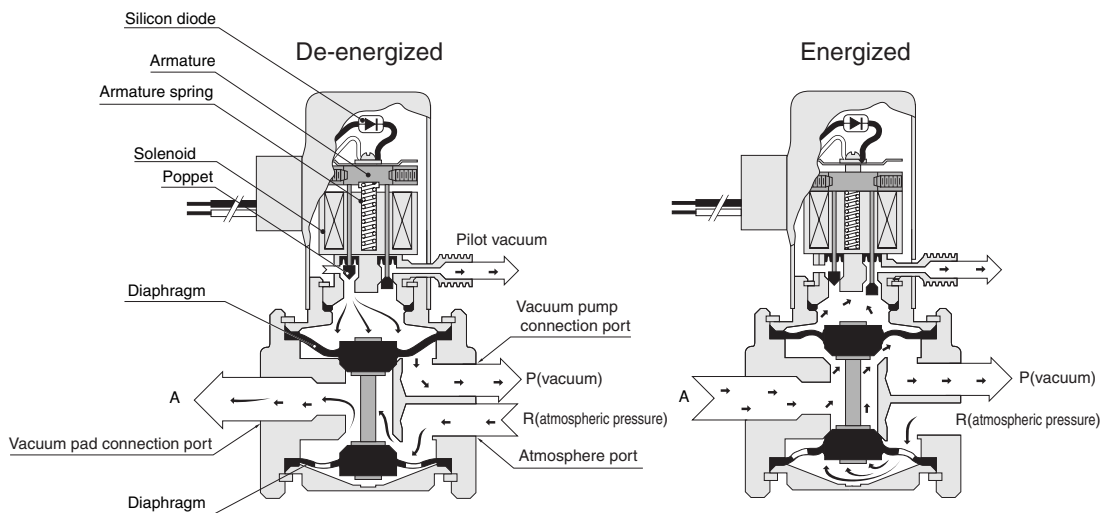

### Explanation of operation

- When de-energized, the armature is separated from the solenoid by the armature spring. The right-side poppet directly connected to the armature closes, and the left-side poppet opens, and the upper diaphragm is pulled downward by the vacuum (main) applied to the bottom surface of the upper diaphragm, closing the P port, and connecting the A port and R port.
- When energized, the armature is attracted to the solenoid, opening the right-side poppet and closing the left-side poppet, applying pilot vacuum to the upper surface of the upper diaphragm. The diaphragm is therefore pulled up, closing the R port, and connecting the P port and A port.

NC	NO
VV500AE1	VV500AE1-11

Dimensions (mm)

VA500AE1

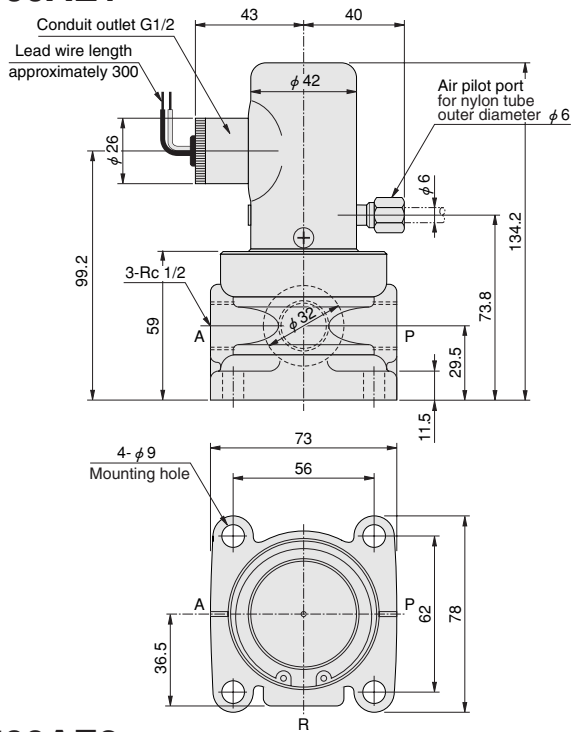

VV500AE1

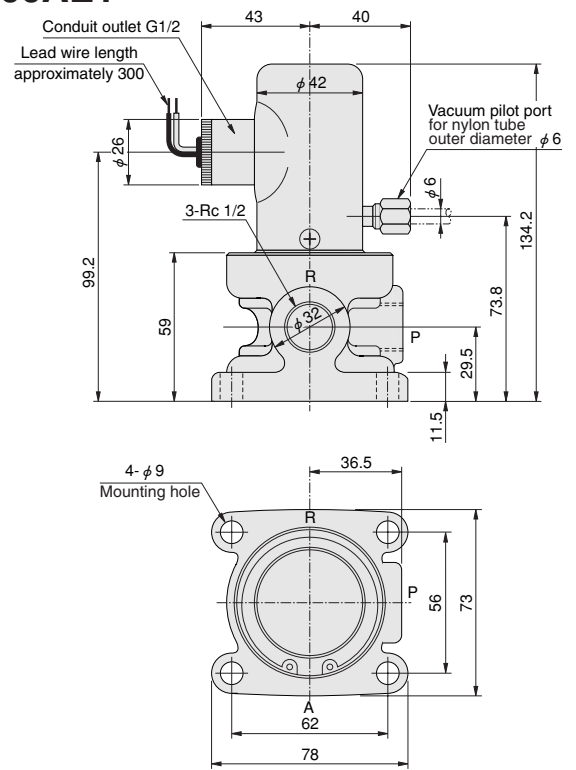

VA500AE2

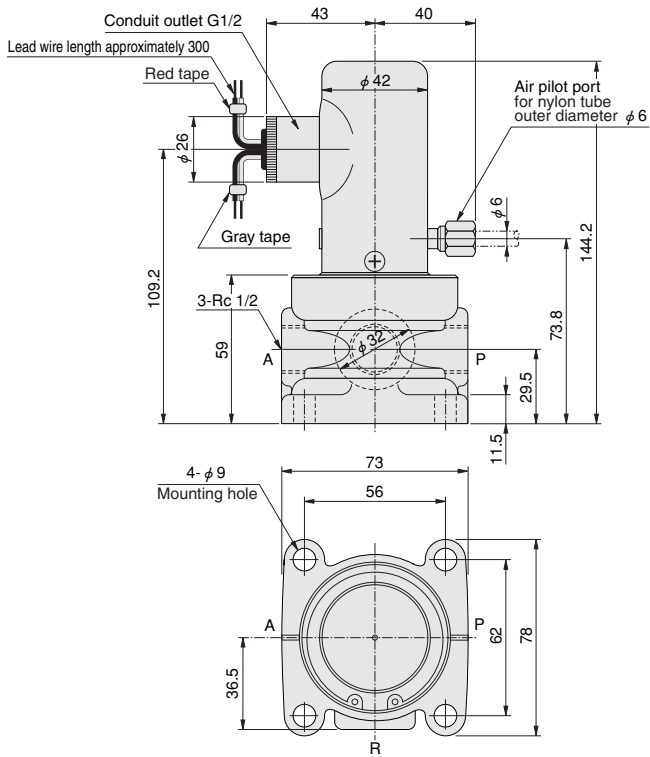

Option -62

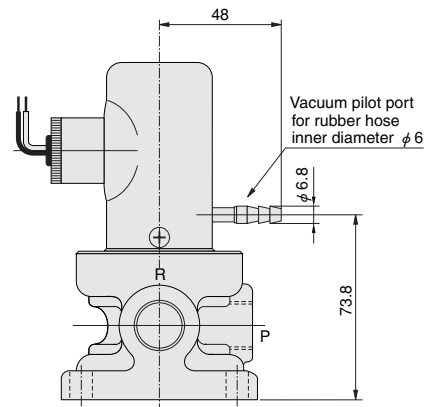



# Reference

## Vacuum Valve Selection Table (Exhaust and Air Supply Response Times)

s

Vacuum kPa [in.Hg]	50cc [3.05in <sup>3</sup> ] chamber				200cc [12.2in <sup>3</sup> ] chamber				1 l [61in <sup>3</sup> ] chamber				3 l [183in <sup>3</sup> ] chamber				5.5 l [336in <sup>3</sup> ] chamber				10.5 l [641in <sup>3</sup> ] chamber			
	Exhaust <sup>Note</sup>		Air supply		Exhaust		Air supply		Exhaust		Air supply		Exhaust		Air supply		Exhaust		Air supply		Exhaust		Air supply	
	0	0	-81.3 [-24.01]	-42.6 [-12.58]	0	0	-81.3 [-24.01]	-42.6 [-12.58]	0	0	-81.3 [-24.01]	-42.6 [-12.58]	0	0	-81.3 [-24.01]	-42.6 [-12.58]	0	0	-81.3 [-24.01]	-42.6 [-12.58]	0	0	-81.3 [-24.01]	-42.6 [-12.58]
Model	-81.3 [-24.01]	-42.6 [-12.58]	0	0	-81.3 [-24.01]	-42.6 [-12.58]	0	0	-81.3 [-24.01]	-42.6 [-12.58]	0	0	-81.3 [-24.01]	-42.6 [-12.58]	0	0	-81.3 [-24.01]	-42.6 [-12.58]	0	0	-81.3 [-24.01]	-42.6 [-12.58]	0	0
V062E1	0.2	0.08	0.18	0.1	0.7	0.35	0.5	0.38	3.0	1.5	2.5	1.8	9.0	3.2	6.0	4.0	20.0	8.0	14.0	10.0				
V126E1	0.12	0.05	—	—	0.4	0.2	—	—	1.8	0.9	—	—	5.0	1.7	—	—	11.0	3.5	—	—				
VA125A	0.1	0.06	0.13	0.12	0.35	0.15	0.3	0.2	1.6	0.7	1.3	0.8	3.8	1.4	2.6	1.8	9.0	3.4	6.0	4.0				
VA250AE1	0.05	0.03	0.09	0.04	0.1	0.05	0.08	0.07	0.5	0.23	0.16	0.18	1.1	0.4	0.7	1.0	2.4	1.0	1.7	1.0				
VA500AE1	0.04	0.03	0.14	0.14	0.07	0.05	0.14	0.14	0.25	0.1	0.15	0.18	0.5	0.2	0.4	0.3	1.1	0.4	0.6	0.5	2.0	0.8	1.0	0.8
1000A2	—																0.26	0.14	0.26	0.2	0.4	0.2	0.4	0.3

Note: The exhaust vacuum in the chamber is a 80% rating value of the vacuum inside of the primary tank.

The above table shows the time it takes from the point in time where the vacuum valve is switched ON to reach the specified vacuum inside of the chamber, and the time from switching the vacuum valve OFF to supply air into the chamber.

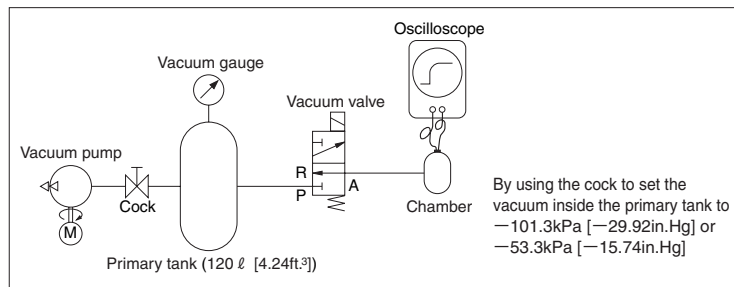

## Standard Vacuum Circuit

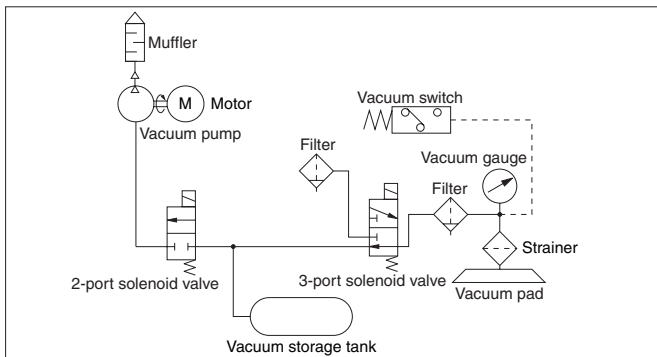

## Inspection Standard for Vacuum Leaks (Koganei standards)

### Inspection procedure

Open valve A, and set the vacuum in the tank to -100kPa [-750mmHg] [-29.53in.Hg]. Afterward, close valve A, let set for 10 minutes, and then check the vacuum inside of the tank both during OFF and ON.

### Inspection standard

Let set for 10 minutes, then check to see that the vacuum leaks inside the tank meets the standard of 1.3kPa (10mmHg) [0.38in.Hg] or less.

For details, consult us.

### Remark

In fact, most Koganei vacuum valves can hold initial vacuum even after being left set for 10 minutes.

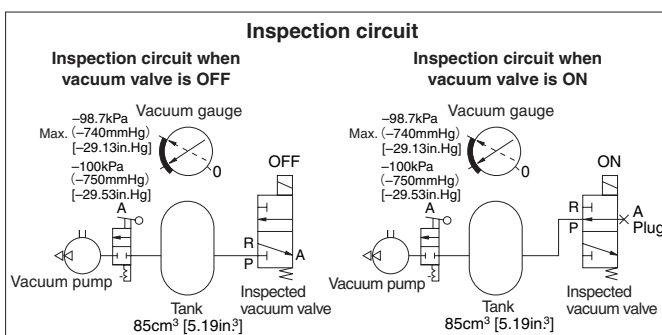

## Calculation of Picking-up Force, and Graph (Theoretical values)

When using a vacuum pad to hold picking-up an object, the picking-up force is shown by the following formula.

$$W = P \times A \times 0.1$$

W: Picking-up force (N)  
P: Vacuum (kPa)  
A: Pad area (cm<sup>2</sup>)

<Conventional units>

$$W' = \frac{P'}{760} \times 1.033 \times A'$$

W': Picking-up force (kgf)  
P': Vacuum (mmHg)  
A': Pad area (cm<sup>2</sup>)

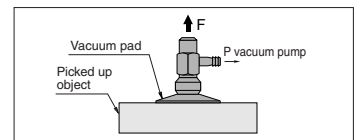

$$W'' = \frac{P''}{29.92} \times 14.7 \times A''$$

W'': Picking-up force [lbf.]  
P'': Vacuum [in.Hg]  
A'': Pad area [in.<sup>2</sup>]

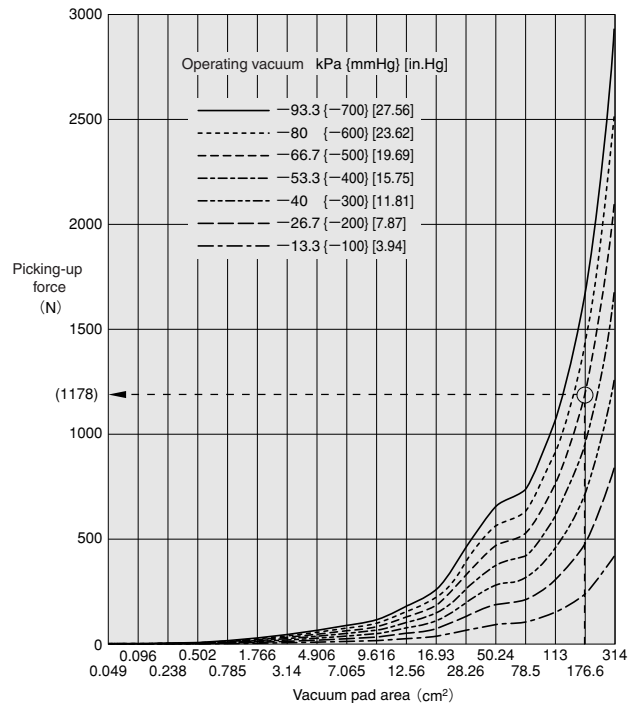

### How to read the graph

When the vacuum is -66.7kPa [-19.7in.Hg], and the vacuum pad area is 176.6cm<sup>2</sup> [27.37in.<sup>2</sup>], the picking-up force is 1178N [265lbf.].



## Reference

### How to Use Both Vacuum and Pressure Type (SV062E1)

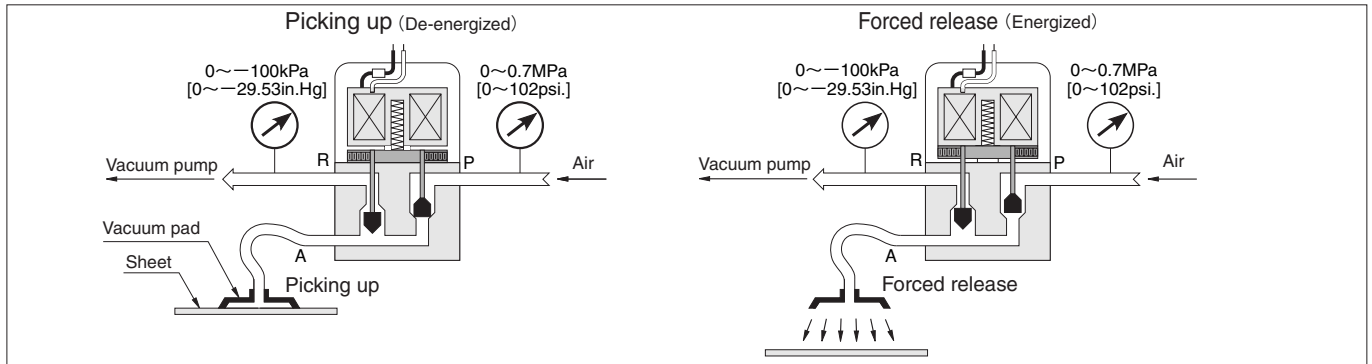

### Application of External Air Pilot Type (VA250AE1/ VA2503AE1/ VA500AE1)

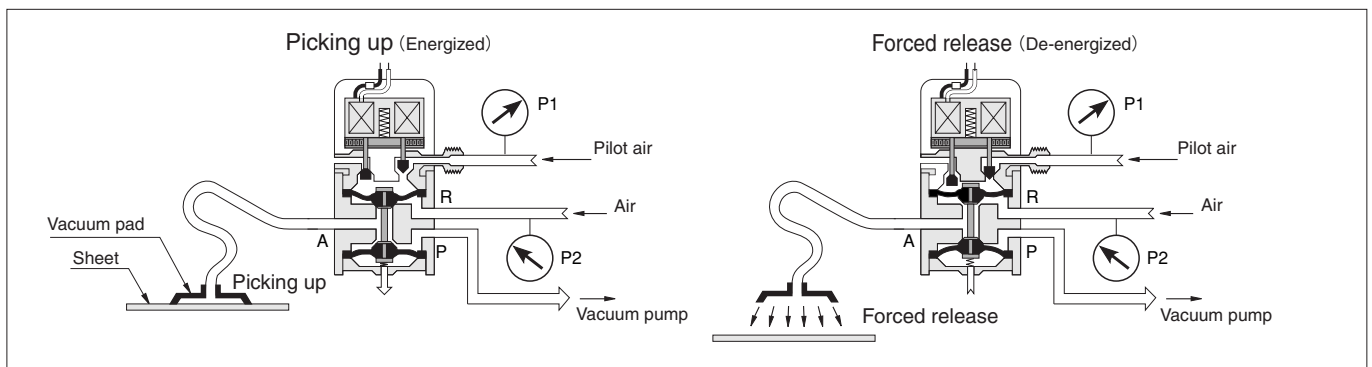

Note: Use as  $P_1 > 2P_2$ .

### Application of External Double Air Pilot Type (250A2 / 500A2, etc.)

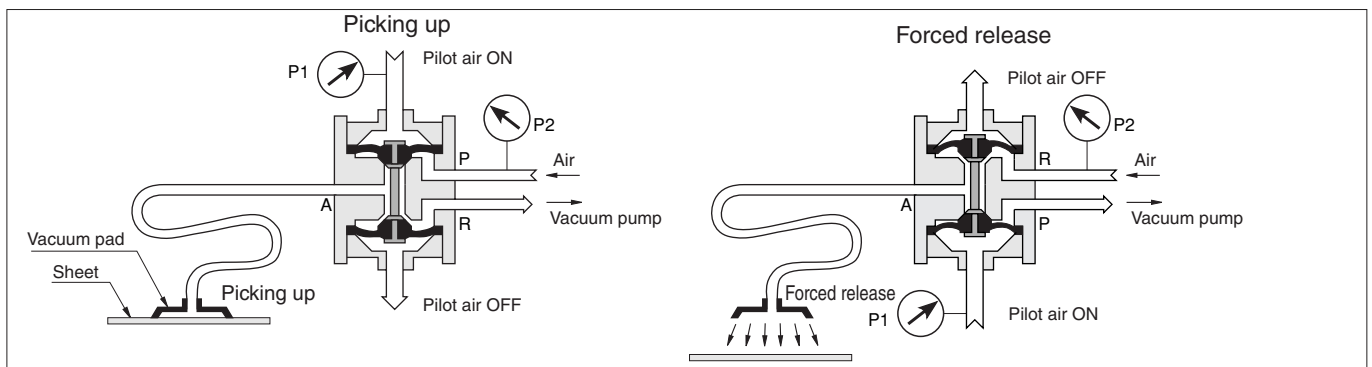

Note: Use as  $P_1 > 2P_2$ .

### Pressure Unit Comparison Table

